

Workplace Return

April 24th , 2020

This document is intended to provide general insight and best practices rather than specific, customized client advice. Further, this document does not constitute legal advice. Employers should engage their own legal counsel to ensure all adopted recommendations are compliant with applicable laws in their jurisdictions, particularly with respect to collection and use of employee health data.

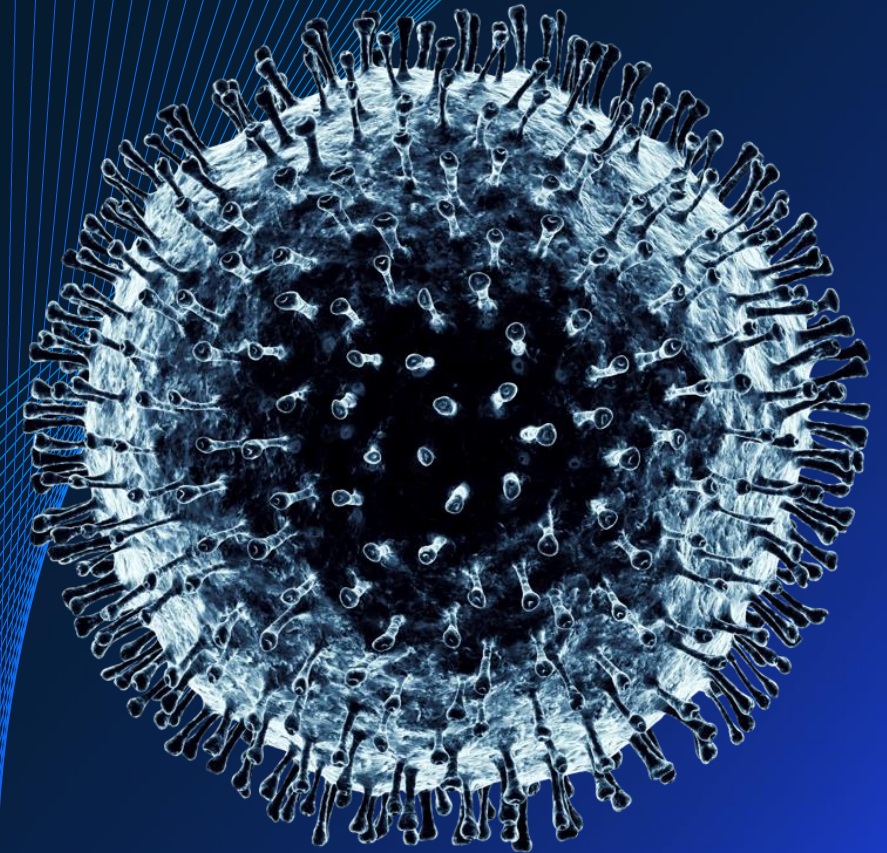

Current as of April 13, 2020

COVID-19 is, first and foremost, a global humanitarian challenge.

Thousands of health professionals are heroically battling the virus, putting their own lives at risk. Governments and industry are working together to understand and address the challenge, support victims and their families and communities, and search for treatments and a vaccine.

Companies around the world need to act promptly.

This document is meant to help senior leaders understand the COVID-19 situation and how it may unfold, and take steps to protect their employees, customers, supply chains, and financial results.

[Read more on McKinsey.com](#) →

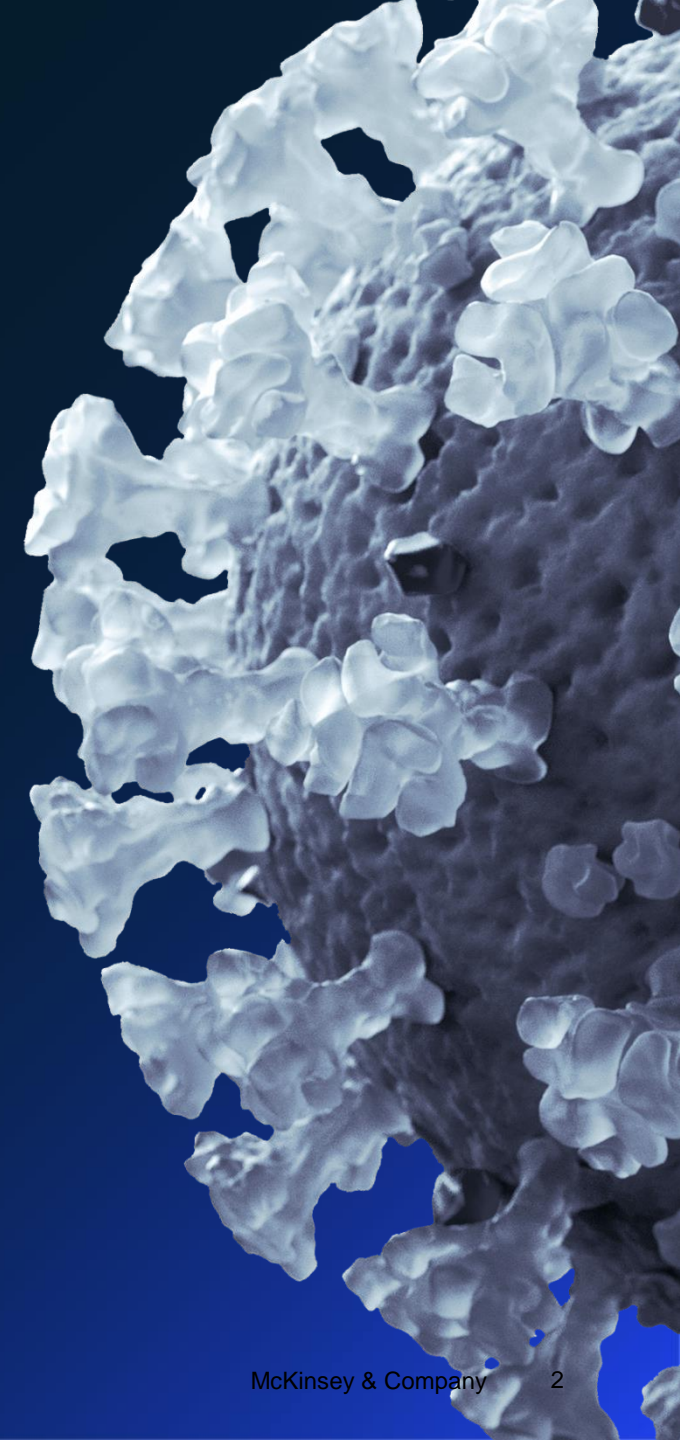

Context & how to use this document

This document reflects a database of interventions that have been used in industry, and have worked for companies around the globe across manufacturing, retail, office and field environments

This document is meant to provide visibility on the measures different organizations are taking to ensure protection across the workforce journey

This document is NOT meant to represent vetted McKinsey recommendation or guidance on best-practices

Organizations should ensure that all local regulations, and country specific circumstances are taken into account before considering implementation of specific interventions

This document compiles ~75 interventions for workforce protection during Return



~75

interventions used worldwide, across

8

levers of protection,

5

phases of the workforce journey, and

4

Environments (office, retail, field, manufacturing)

How to consider transition: Ensuring protection across workforce journey

Workforce protection interventions across manufacturing, office, retail and field environments

Pre-entry

- Policy and education
- Workforce communication



Travel to work

- Public, employer-sponsored and individual transport
- Entrance controls



At work

- Manufacturing environment
- Office environment
- Retail environment
- Field environment



Common spaces

- Meeting rooms
- Break rooms
- Hallways
- Restrooms
- Other







Post-infection

- Isolation
- Tracing & isolation
- Facility response
- Insurance
- Liability



Initiative tracker across the workforce journey

Pre-entry	 Travel to work	 At work	 Common spaces	 Post-infection
Separate in space & time	<ul style="list-style-type: none"> 17 Increase safety protocol 18 Use private transport 19 Stagger entry 20 Entry controls 24 Limit on-site capacity 25 Restrict non-employee entry 27 Separate hours for vulnerable populations 	<ul style="list-style-type: none"> 32 Stagger work shifts 39 Physical separation of workstations 40 Physical separation through zones 42 Critical function teams 45 Implement one-way store aisles 47 Separation between customers 49 Minimize person-to-person contact 	<ul style="list-style-type: none"> 70 Close common areas 73 Limit capacity in elevators 83 Stagger lunch hours 84 Cafeteria physical distancing 87 Dormitory safety practices 	<div data-bbox="2125 225 2433 1335" style="border: 1px solid black; height: 777px; width: 121px;"></div> <p>Content being developed</p>
Drive safe behavior norms	<ul style="list-style-type: none"> 30 Mental health services 	<ul style="list-style-type: none"> 46 Reduce in-store services 41 "Remote-first" practices 50 Institute a clean desk/ work station 51 Limit larger gatherings 52 Move in-person processes to digital 53 Monitor policy adherence 63 Alter return and cancellation policies 	<ul style="list-style-type: none"> 68 walkthrough assessment 72 Limit larger gatherings of employees 75 Monitor policy adherence 88 Establish team or communication chain 	
Use protective equipment	<ul style="list-style-type: none"> 28 Encourage or mandate PPE gear 	<ul style="list-style-type: none"> 36 Encourage or mandate PPE gear 	<ul style="list-style-type: none"> 79 Encourage or mandate PPE gear 	
Test & isolate	<ul style="list-style-type: none"> 11 At-home surveys 	<ul style="list-style-type: none"> 14 At-home surveys 22 Temperature testing at Entry 		
Increase awareness	<ul style="list-style-type: none"> 12 What to expect when returning 13 Two-way communication channels 14 Completed return to work trainings 15 Safe commute and wellness practices 	<ul style="list-style-type: none"> 23 Clearly communicate safety protocols at entry 	<ul style="list-style-type: none"> 34 Promote healthy personal habits 35 Use prominent displays highlighting new processes and policies 	
Clean & disinfect	<ul style="list-style-type: none"> 26 Provide disinfectants 	<ul style="list-style-type: none"> 33 Reduce operating hours to clean 44 Provide cleaning equipment 53 Frequent cleaning 55 High-visibility cleaning 57 Deep-cleaning 	<ul style="list-style-type: none"> 76 High-visibility cleaning 78 Deep-cleaning 86 Increase hygiene protocols 	
Upgrade equipment		<ul style="list-style-type: none"> 48 Contactless thermometer 58 Improve air filtration / ventilation 59 Install plexiglass barriers 60 "Dark stores" 61 Contactless payment 62 Implement curbside pick ups 	<ul style="list-style-type: none"> 69 Remove communal resources 71 Minimize handles 74 Improve air filtration 85 Replace communal food options 	

Sample journey: Manufacturing environment

Travel to work and pre-entry

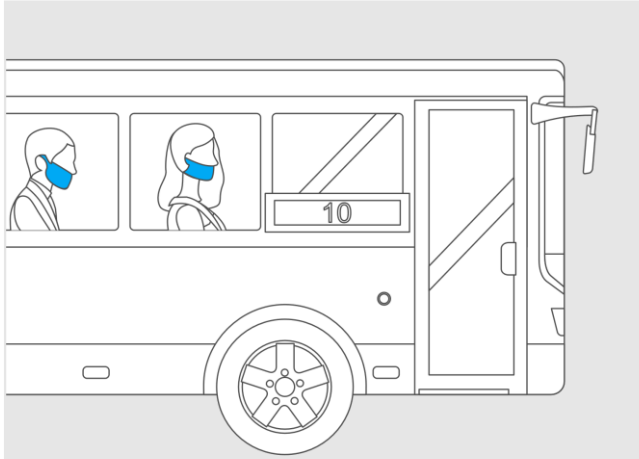

Use of masks required during employee commutes

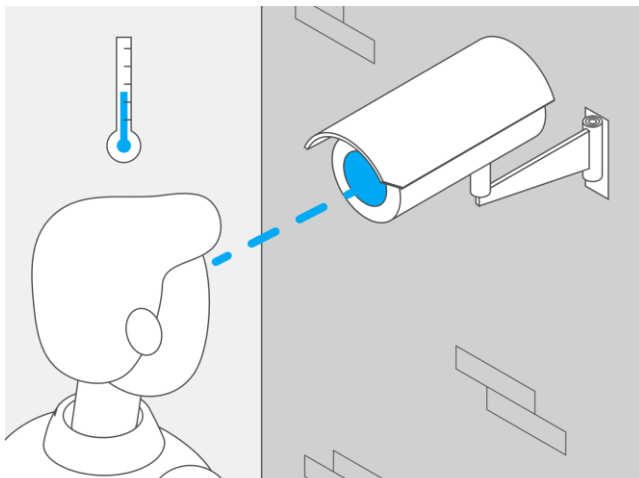

Temperature checks

At Work

Modularized spaces, with limited interaction across spaces

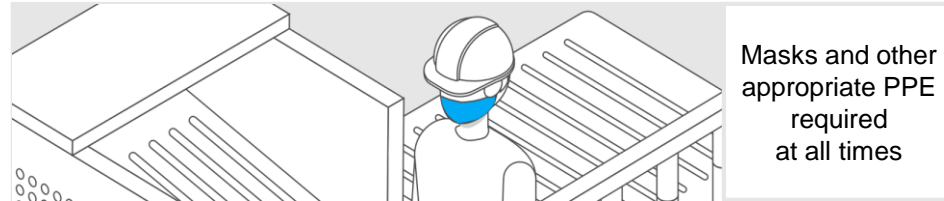

Masks and other appropriate PPE required at all times

High-frequency cleaning of high-touch surfaces and spaces

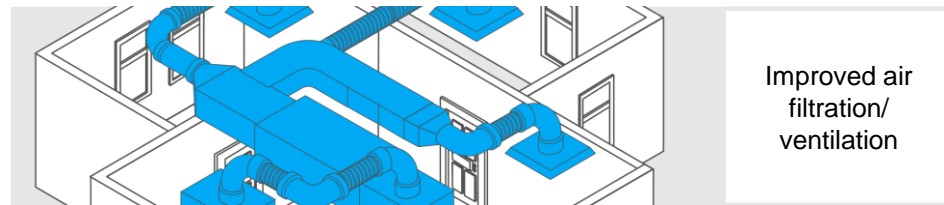
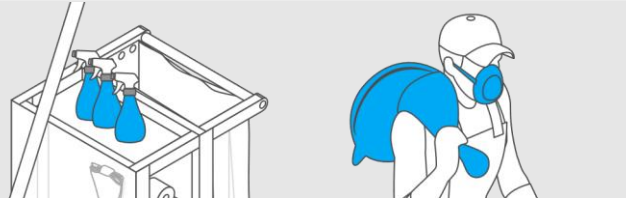

Improved air filtration/ventilation

Clear posters on safety guidance and sickness protocols

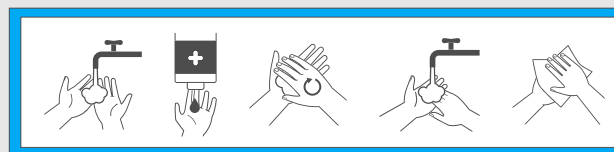

Common space use

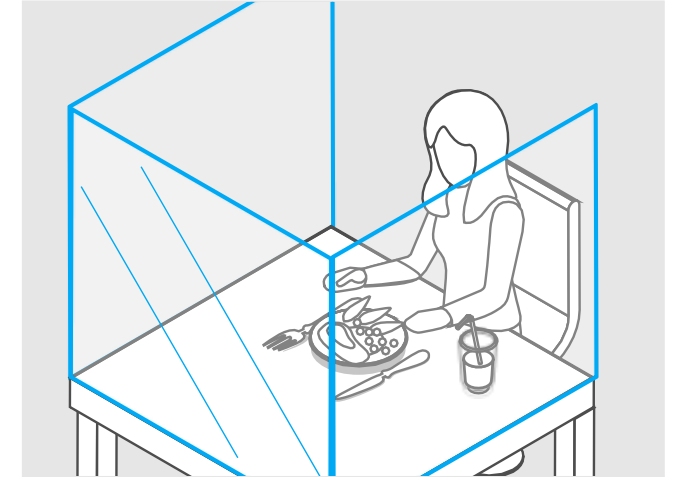

Separated lunch seating with dividers on dining tables

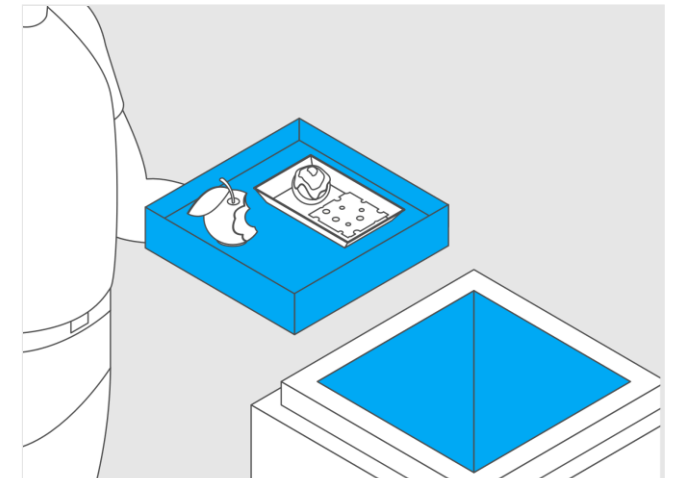

Use of non-reusable dishes at cafeterias

Sample journey: Office environment

Travel to work and pre-entry

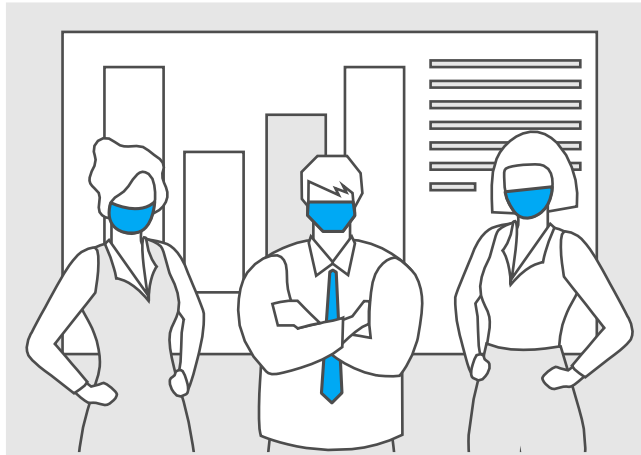

Masks required and provided for employees

At Work

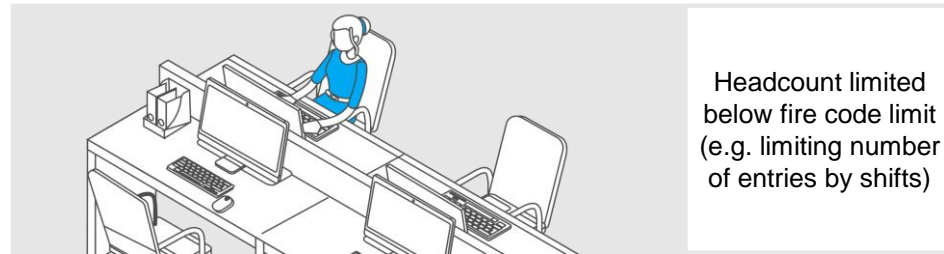
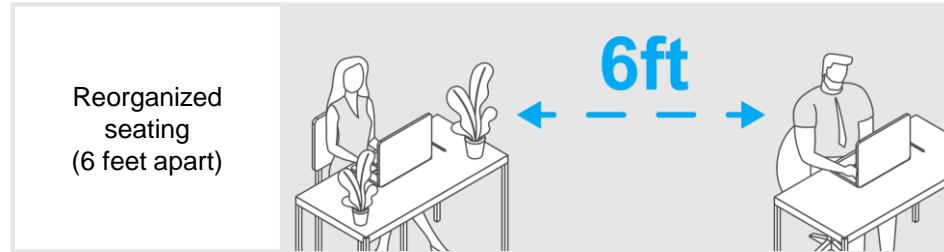

Common space use

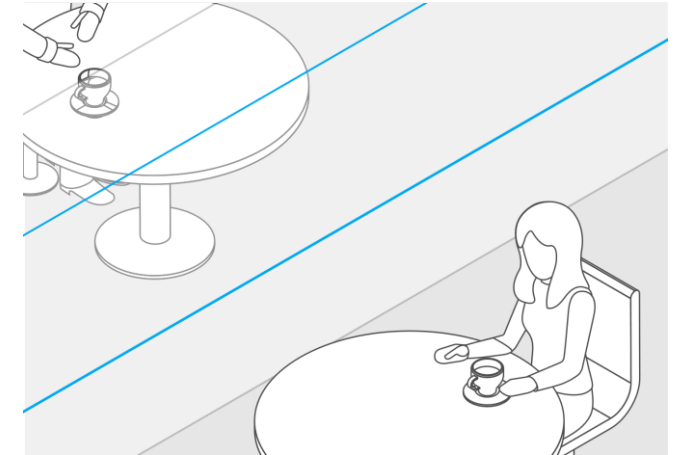

Separated lunch seating

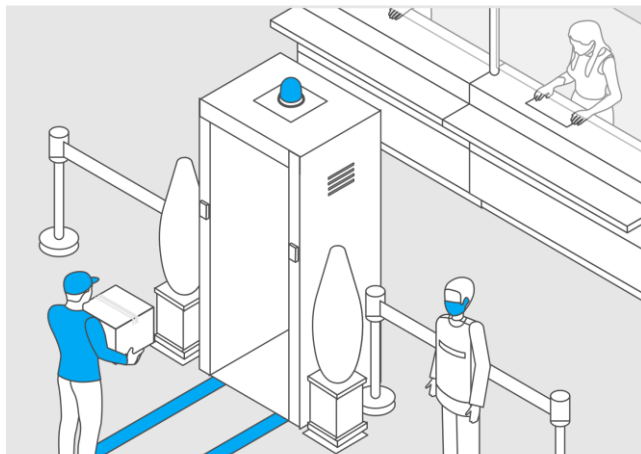

Limited entrance for non-employees

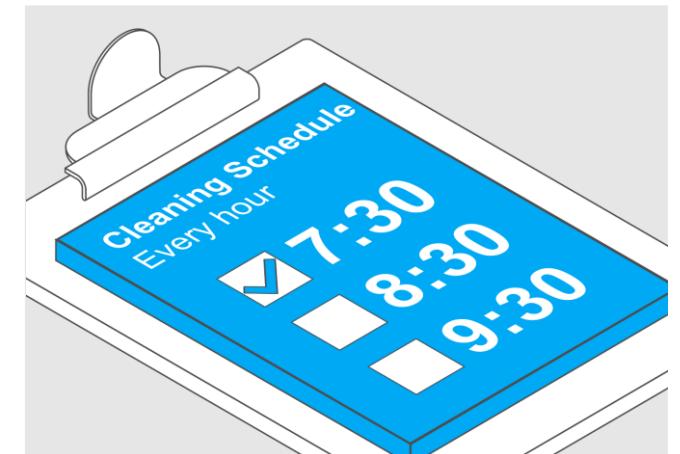

Increased frequency cleaning with visibly monitored cleaning schedules

Sample journey: Retail environment

Travel to work and pre-entry

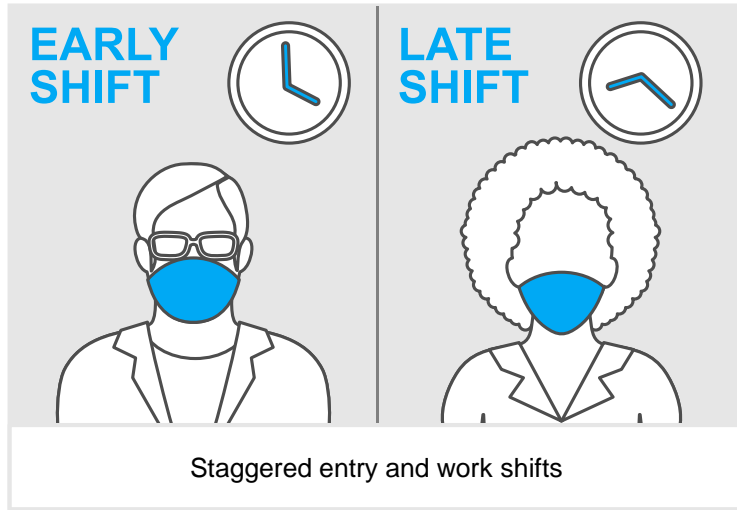

At Work



Common space use

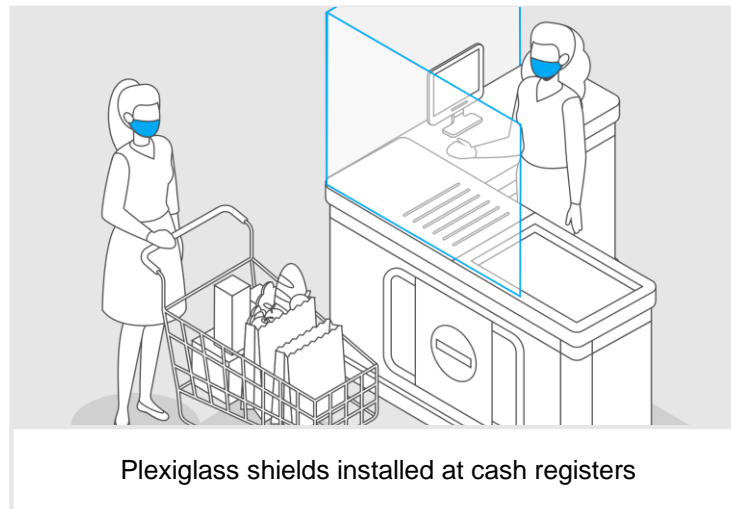
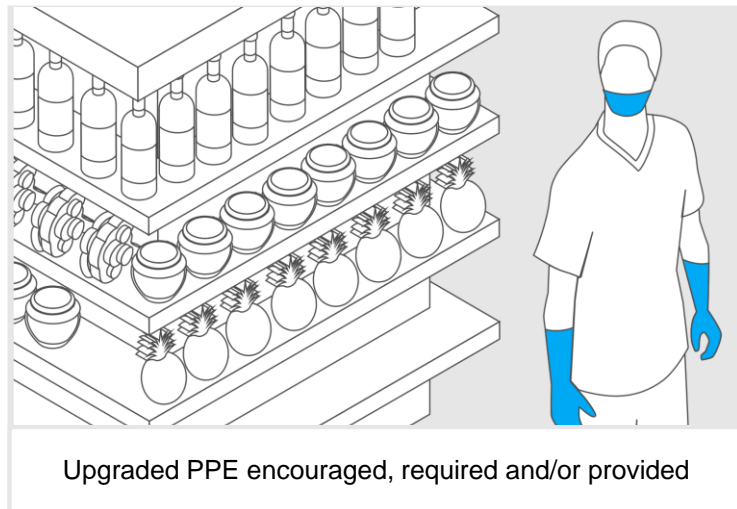

Pre-entry

Periodic health risk categorization through at-home surveys

Test & isolate

Office | Field

Description of potential intervention

Send out online **health self-assessment program** to fill it out to all employees every Sunday regarding COVID-related symptoms

- Those who do not reply would be separately examined at the entrance of company facilities the next day
- Survey helps determine health risk of employees and advises readiness to return to work

Opt-in program for subsidized **connected thermometers** system for early warning

Where this has been done

South Korean conglomerates

Corporate offices in China

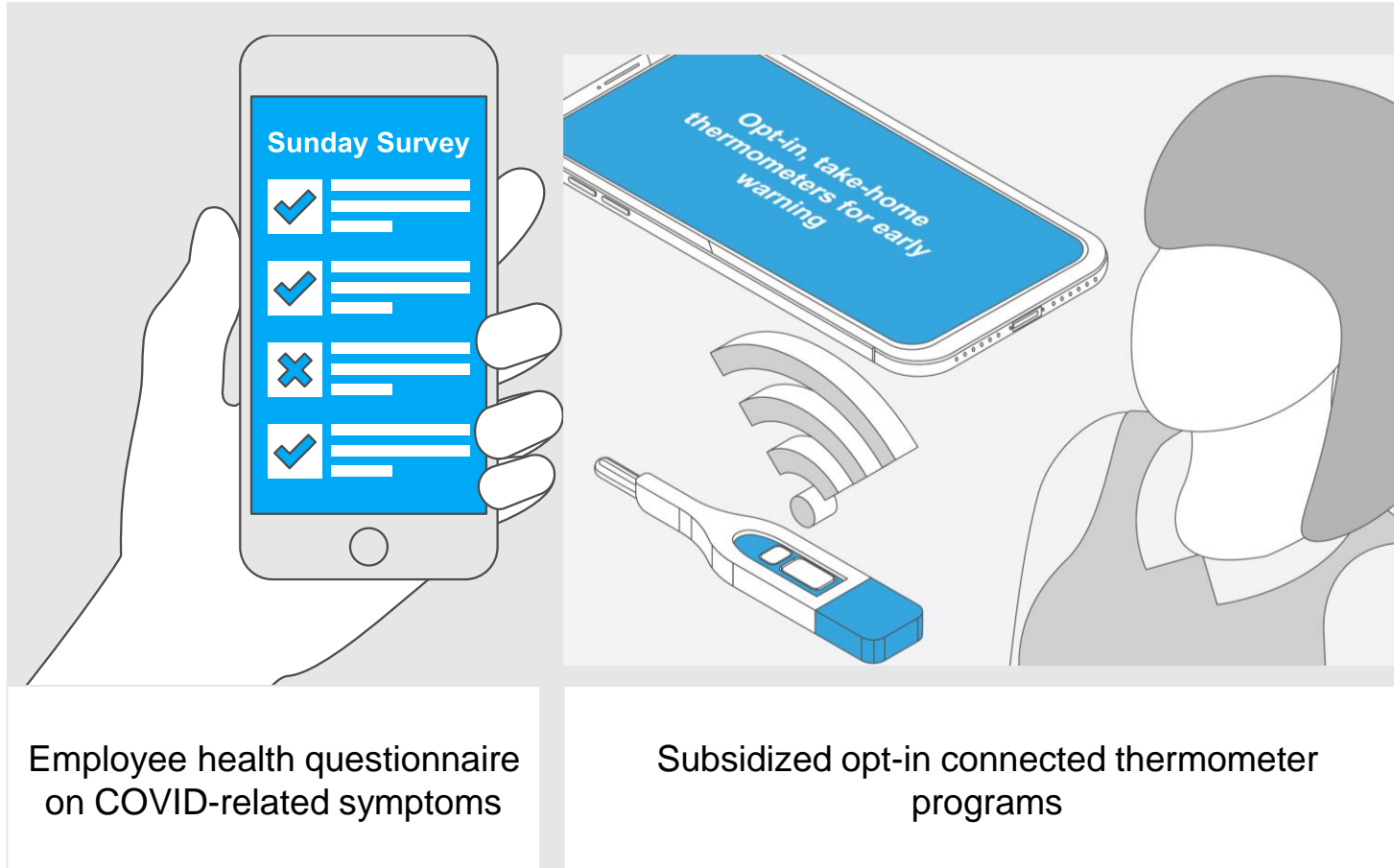

Employee health questionnaire on COVID-related symptoms

Subsidized opt-in connected thermometer programs

Does not reflect McKinsey guidance customized to individual client needs - should be vetted against applicable legal and business requirements before application to a specific client

Source: Expert interviews, press search, client surveys

Share with and train employees on what to expect when returning to the workplace

Increase awareness

Office | Field

Description of potential intervention

Use online and remote channels to share with employees what to expect when returning to the workplace. Include information on:

- **Sick leave, compensation and related updated policy guidance**
- **Database on resources and support available** to employees (mental health, childcare, policy guidelines, privacy safeguards)
- **Information on new work practices, infrastructure** and changes to daily schedule and operations
- **Personal wellness** guidance for outside of the work place

Where this has been done

Corporate offices in the U.S. when initially moving to remote working

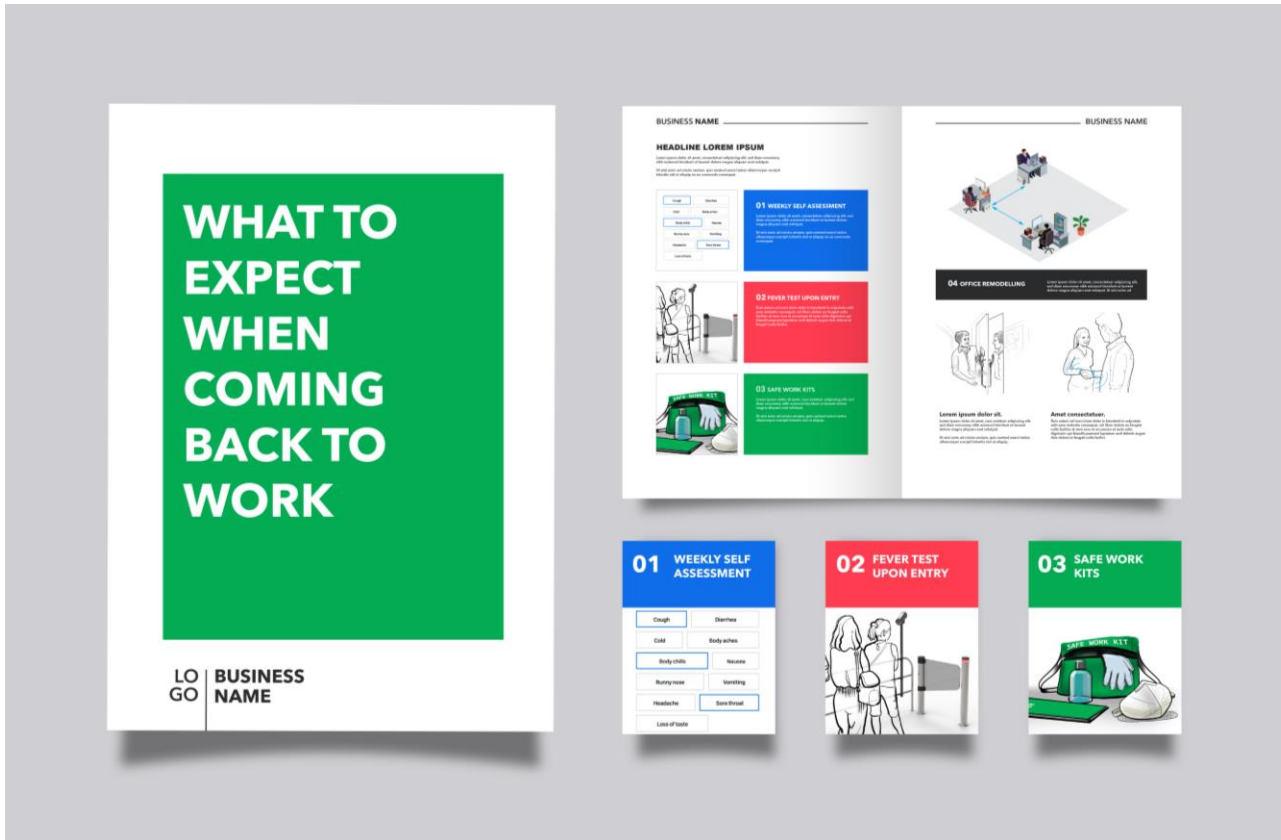

Does not reflect McKinsey guidance customized to individual client needs - should be vetted against applicable legal and business requirements before application to a specific client

Source: Expert interviews, press search, client surveys

Establish two-way communication channels as employees prepare for return

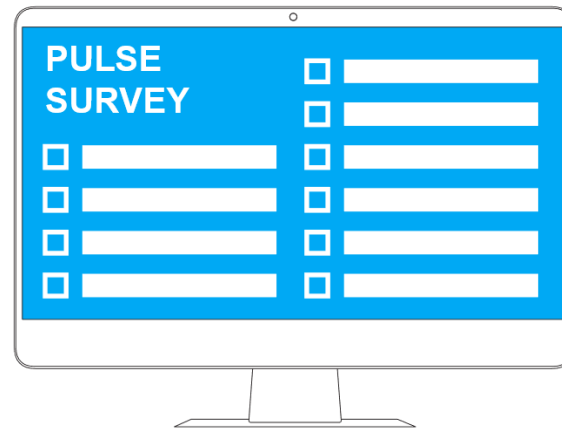
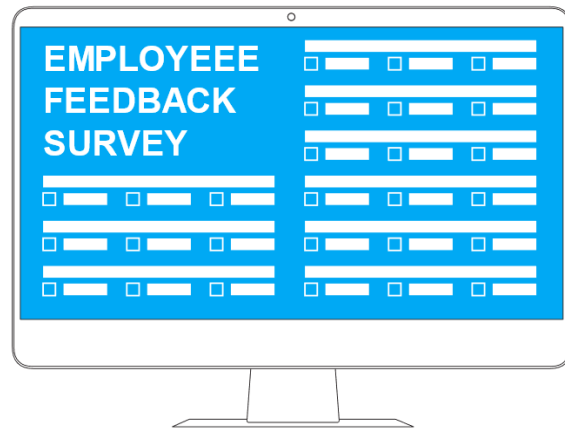
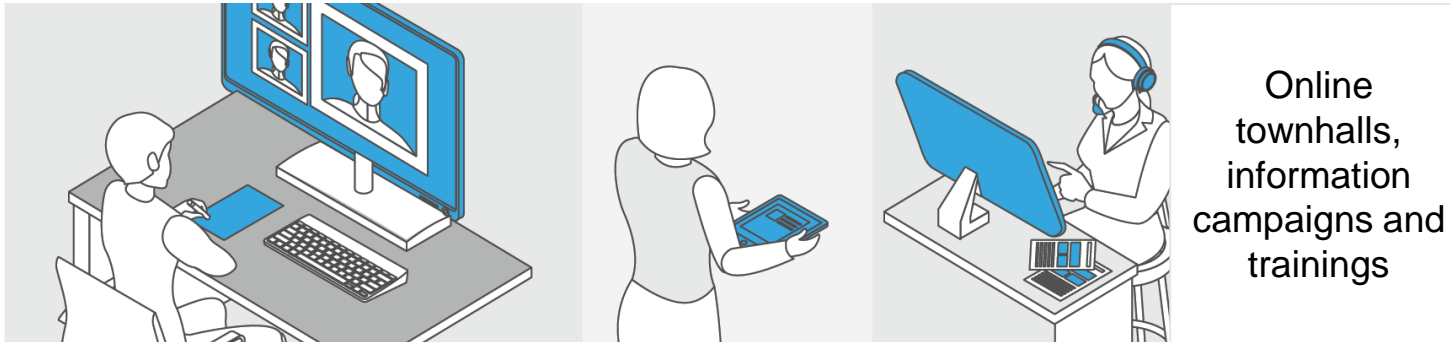

Increase awareness

Office | Field

Description of potential intervention

Develop online modules and trainings to ensure employees have adequately understood all new guidelines and resources

Conduct virtual townhalls with leadership to address questions on a company-wide forum and ensure clarity of message to workforce

Proactively survey employees to gather feedback on measures adopted and to inform new workplace safety measures

Share pre-packaged print material (consistent with displays and posters used in the workplace)

Where this has been done

Corporations in the U.S.

Does not reflect McKinsey guidance customized to individual client needs - should be vetted against applicable legal and business requirements before application to a specific client

Source: Expert interviews, press search, client surveys

Ensure employees have completed all return to work trainings prior to entry

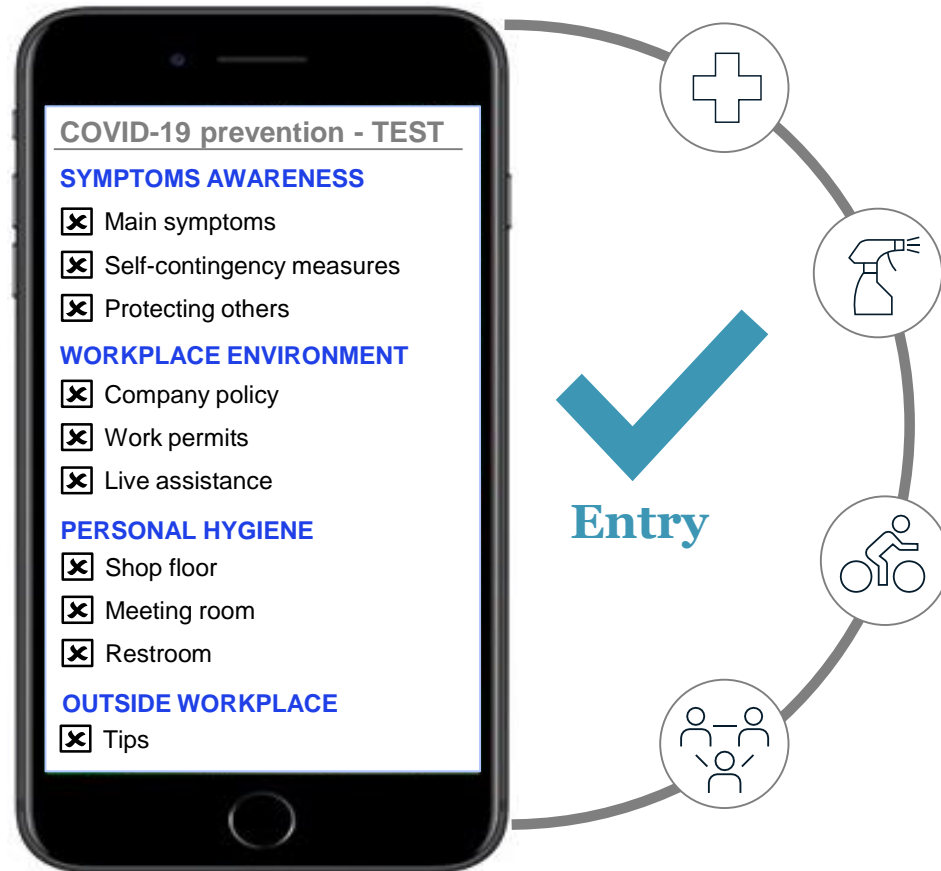

App-based test training

Increase awareness

Office | Field

Description of potential intervention

Allow entrance to worksite only after passing an app-based test training provided to workers on prevention measures

Where this has been done

Corporate offices in China

Does not reflect McKinsey guidance customized to individual client needs - should be vetted against applicable legal and business requirements before application to a specific client

Source: Expert interviews, press search, client surveys

Educate employees on safe commute, work and personal wellness practices

Increase awareness

Office | Field

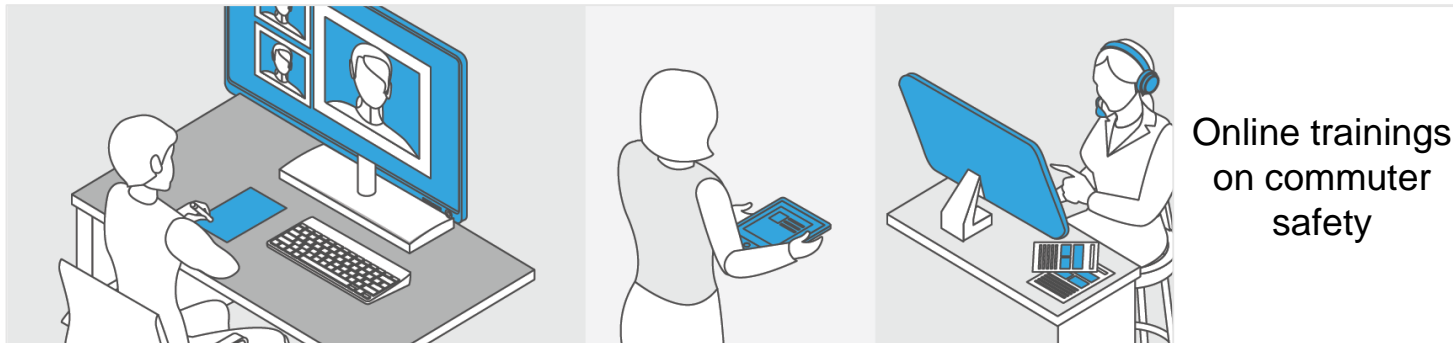
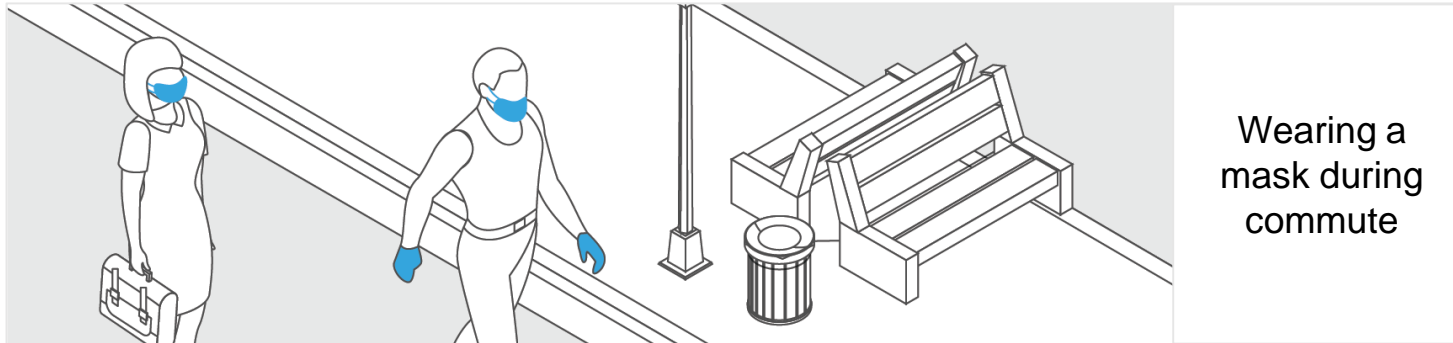

Description of potential intervention

Train employees on commuter safety practices such as wearing masks in public, avoiding rush hour, choosing to walk for part of the trip, etc.

Require use of PPE on commute in to work

Provide employees with sanitation packs to be used for public transport such as mini sanitizers, quick access wipes and gloves

Train employees on best practices for cleaning and disinfecting following use of public transport and prior to entry

Where this has been done

Multiple organizations worldwide

Does not reflect McKinsey guidance customized to individual client needs - should be vetted against applicable legal and business requirements before application to a specific client

Source: Expert interviews, press search, client surveys

Travel to work

Increase safety protocol in company sponsored travel

Separate in space & time

Office | Field

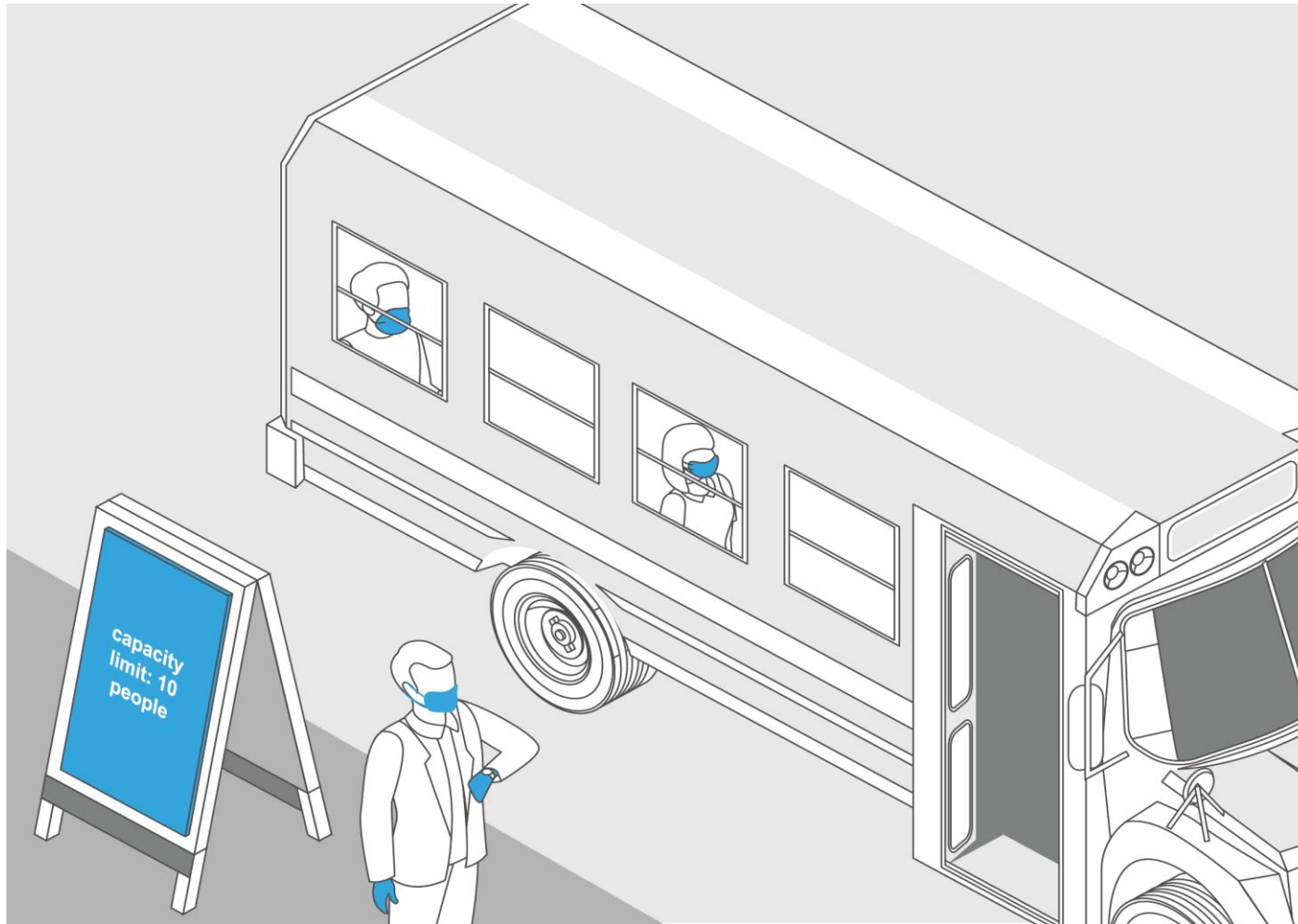

Description of potential intervention

Restrict seating on company operated shuttles to half capacity

Temperature check employees prior to boarding the shuttle

Disinfect shuttle vehicle after each trip. Provide disinfecting kits and PPE to shuttle operators/drivers

Where this has been done

Factories in China

Does not reflect McKinsey guidance customized to individual client needs - should be vetted against applicable legal and business requirements before application to a specific client

Source: Expert interviews, press search, client surveys

Encourage employees to use private transport where possible

Separate in space & time

Office | Field

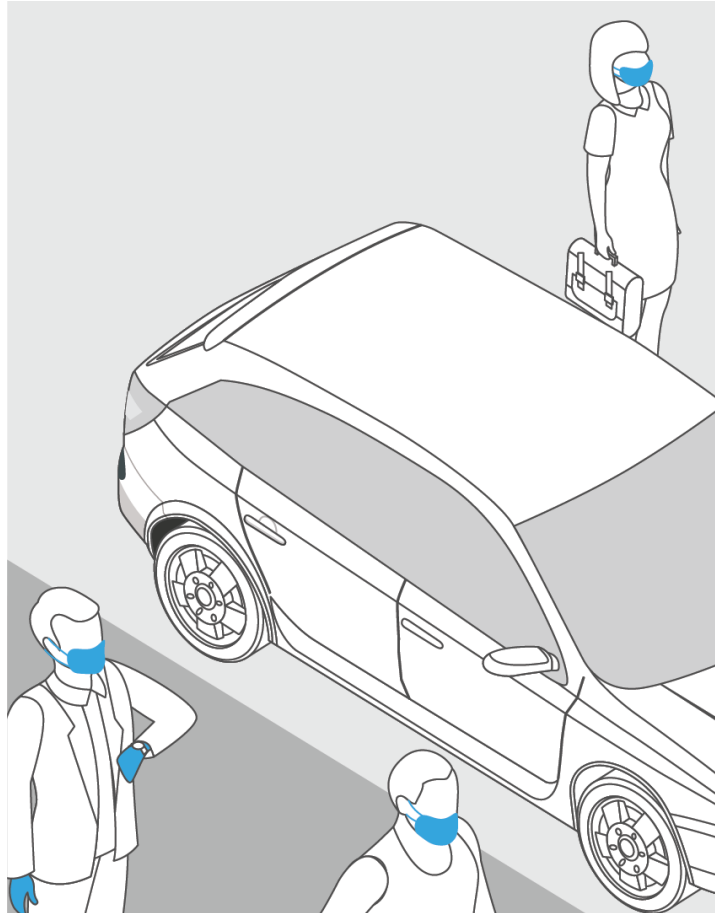

Walking or private transport

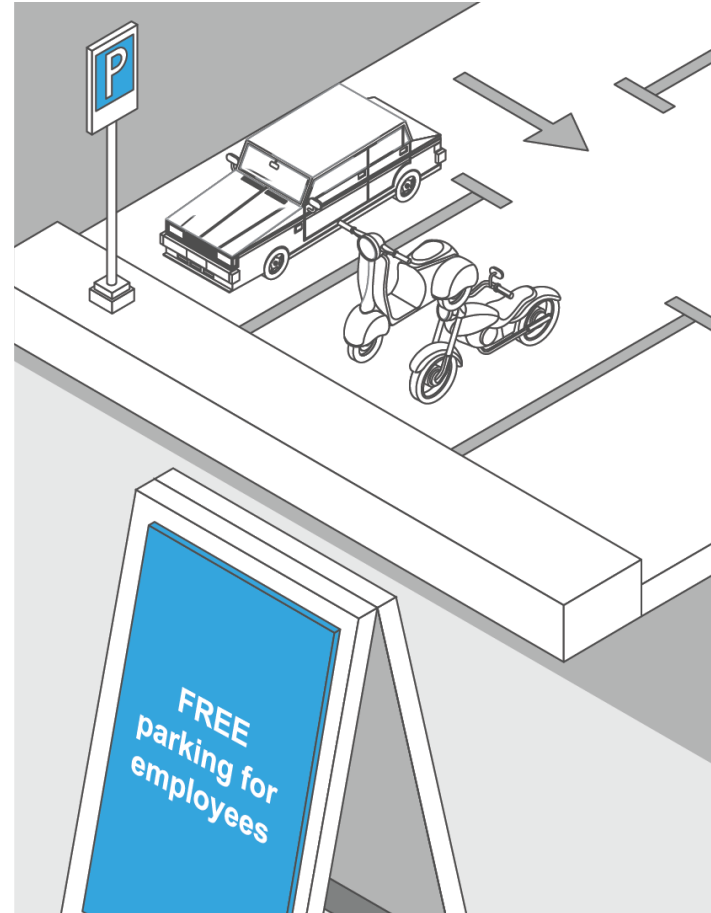

Subsidize parking at workplace

Description of potential intervention

Encourage walking or private transport when feasible for commute (over public transportation)

Subsidize parking at workplace – increase capacity if necessary

Provide gas subsidies for employees driving to work

Where this has been done

Corporate offices in Asia

Does not reflect McKinsey guidance customized to individual client needs - should be vetted against applicable legal and business requirements before application to a specific client

Source: Expert interviews, press search, client surveys

Stagger entry for employees and customers

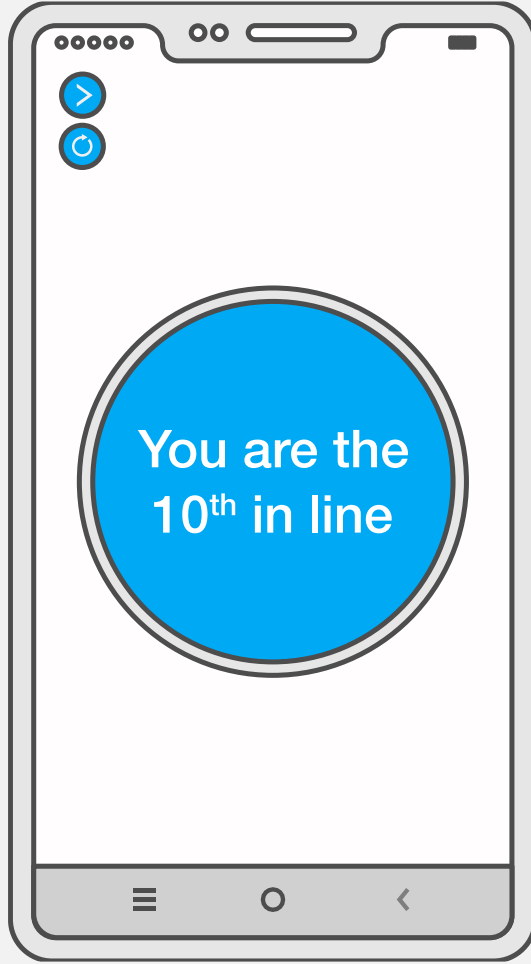

Does not reflect McKinsey guidance customized to individual client needs - should be vetted against applicable legal and business requirements before application to a specific client

Source: Expert interviews, press search, client surveys

Separate in space & time

Office | Field

Description of potential intervention

Institute a 'Flexible Commuting' policy for all employees to avoid rush hours and stagger entry windows

Adopt virtual waiting areas or online appointment scheduling to reduce congestion at entry

Where this has been done

Grocery stores in the US

Restaurants and museums in China, S. Korea

Increase controls at entry point (1/2)



Camera controlled entry

Separate entry and exit

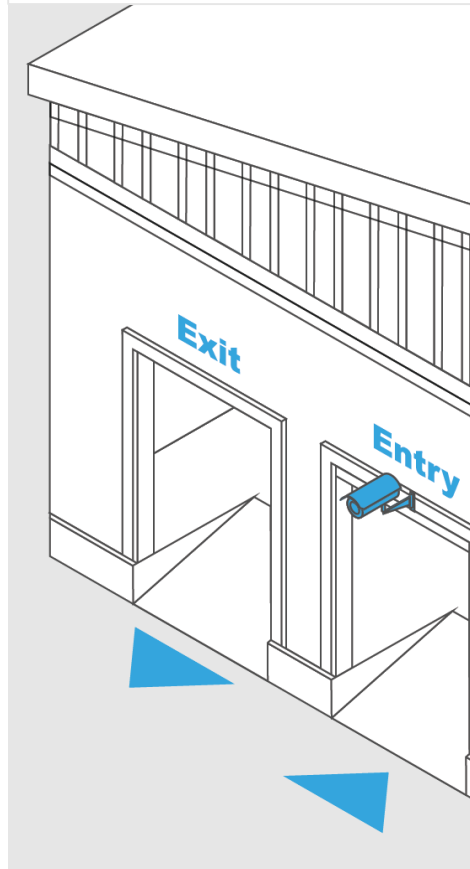

Maintain physical distancing in entry queue

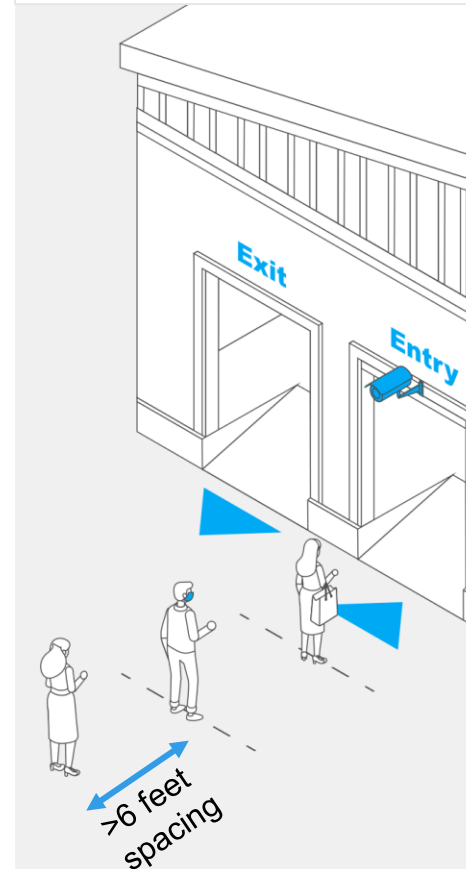

Separate in space & time

Office | Field

Description of potential intervention

Maintain 6 ft distance between individuals lining up for entry

Camera controlled entry to the building after entry criteria is met to prevent congestions

Separate points of entry and exit to minimize and streamline contact between employees

Where this has been done

Factories across China

South Korean conglomerate

Grocery stores across the U.S.

Does not reflect McKinsey guidance customized to individual client needs - should be vetted against applicable legal and business requirements before application to a specific client

Source: Expert interviews, press search, client surveys

Increase controls at entry point (2/2)

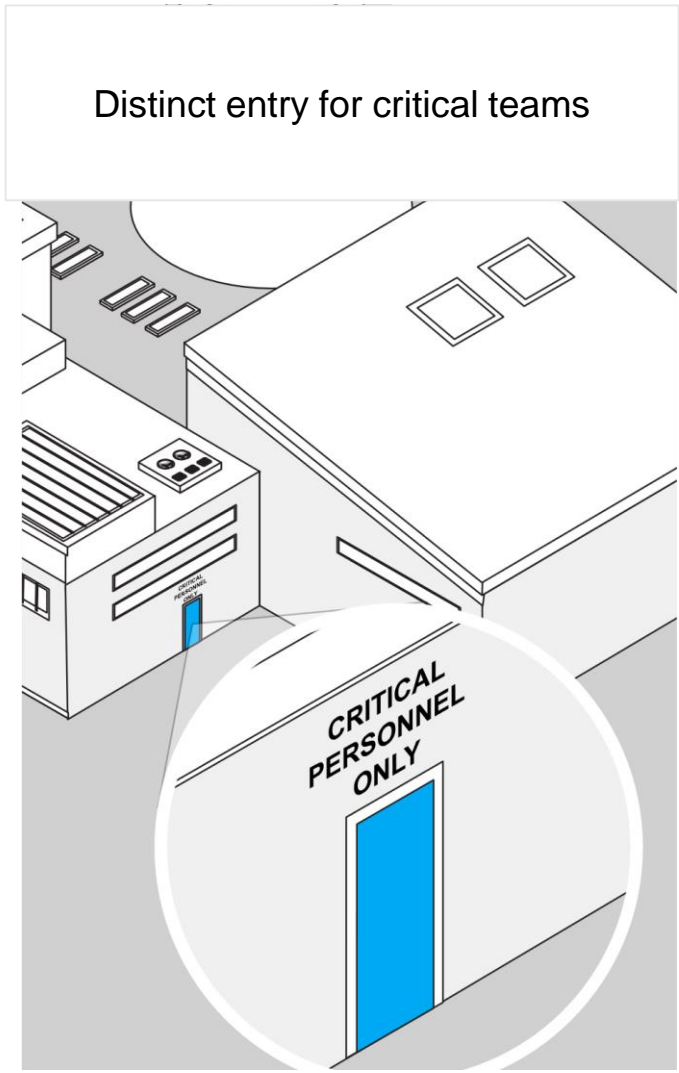

Separate in space & time

Office | Field

Description of potential intervention

Dedicate building entrances for specific teams / functions to minimize overlap and exposure:

- For all critical personnel
- For personnel working in the control room
- For specific groups of teams

Where this has been done

Utilities companies in the U.S.

Market operators in the U.S.

Does not reflect McKinsey guidance customized to individual client needs - should be vetted against applicable legal and business requirements before application to a specific client

Source: Expert interviews, press search, client surveys

Temperature testing stations at entry

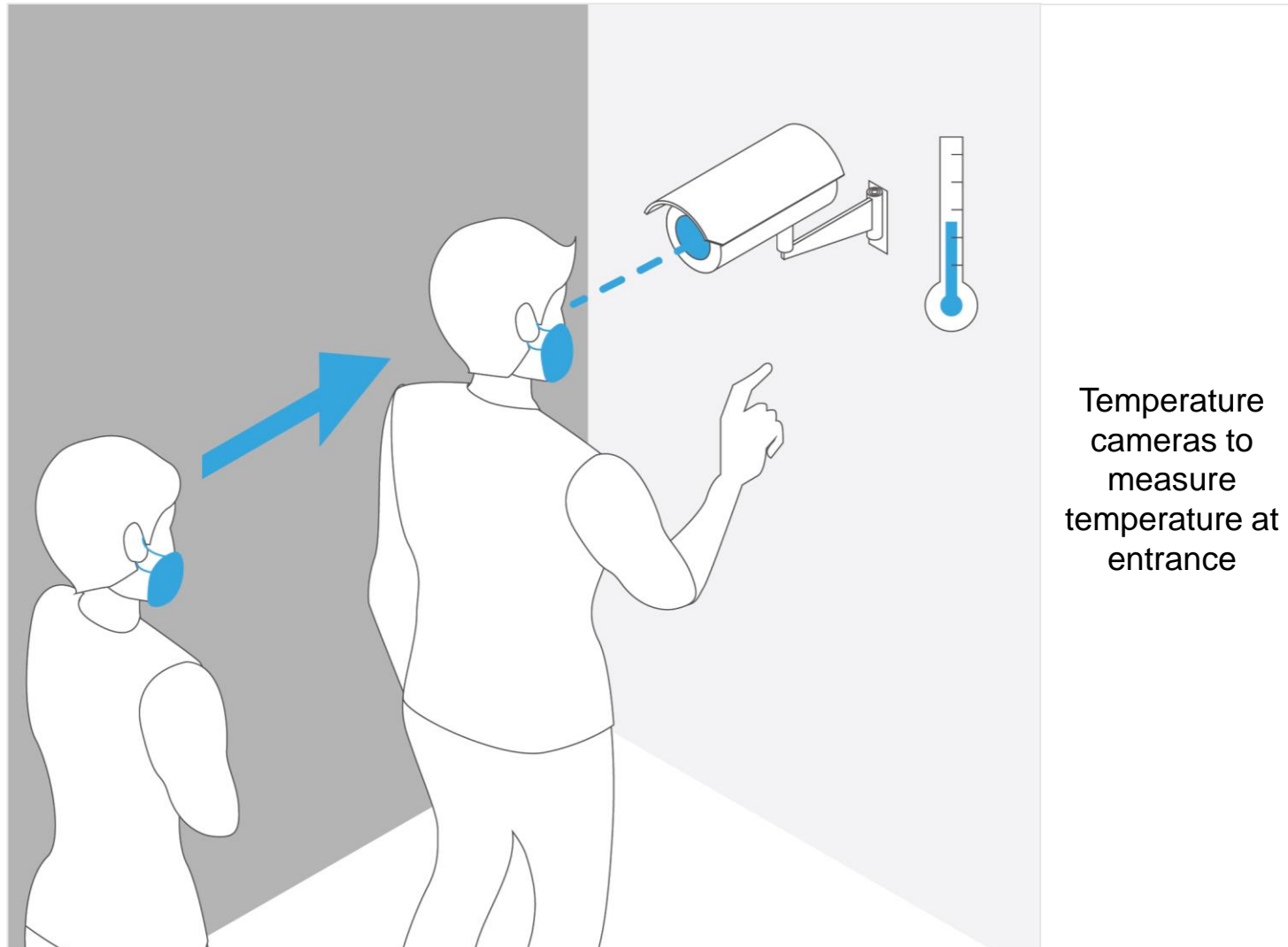

Does not reflect McKinsey guidance customized to individual client needs - should be vetted against applicable legal and business requirements before application to a specific client

Source: Expert interviews, press search, client surveys

Test & isolate

Office | Field

Description of potential intervention

Conduct temperature checks of employees

Heat-sensing camera implemented at entrance that tracks temperature of employees

QR code scanner at entry to confirm employees have passed health criteria (e.g., COVID-symptoms, not on quarantine list)

Where this has been done

Manufacturing plants for S. Korean conglomerates

Corporate offices/Restaurant operators in China

Multinational clothing retail stores in China

Clearly communicate safety protocols at entry

Increase awareness

Office | Field

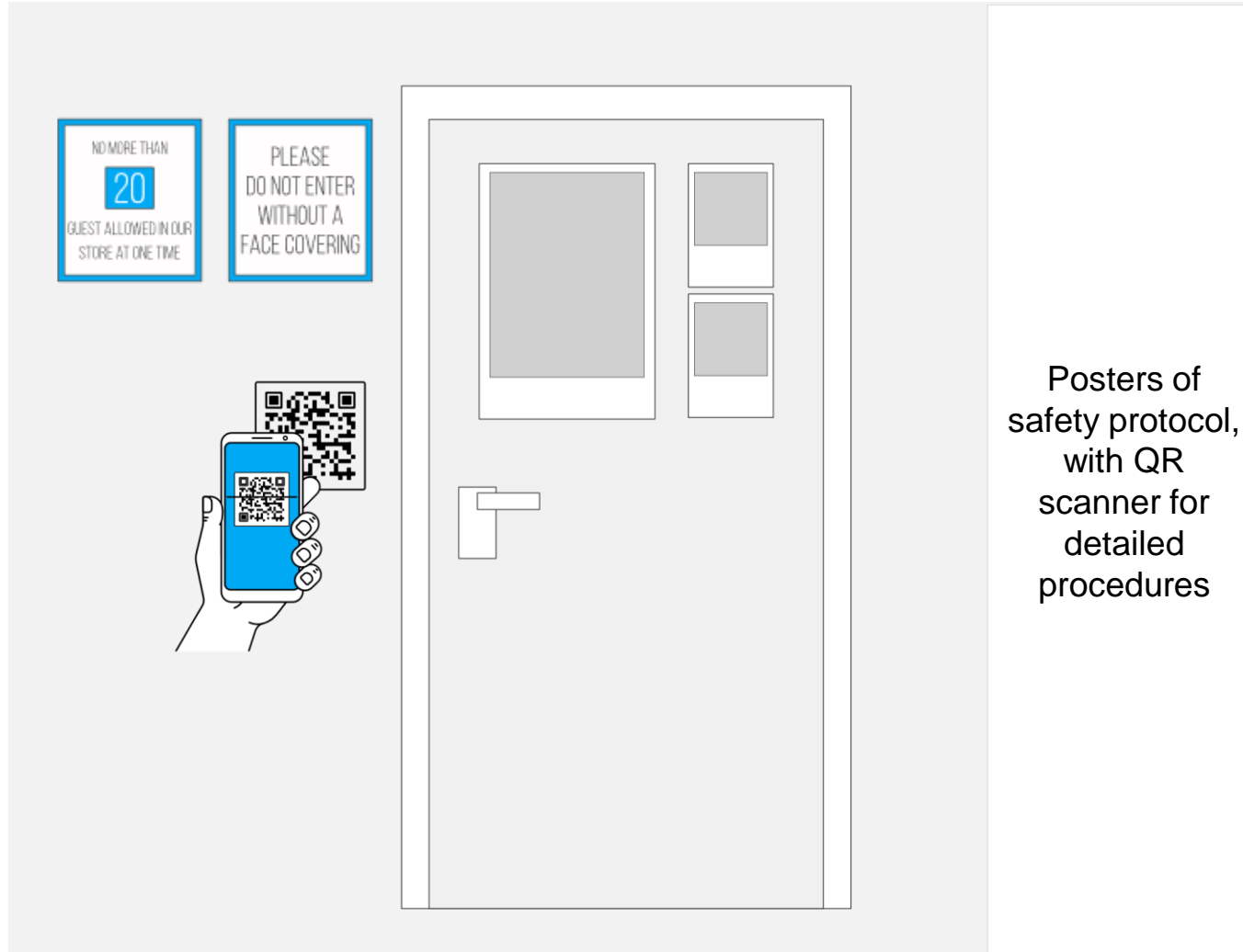

Description of potential intervention

Hang posters at entry points as part of broader information and learning campaign

Place QR code on the door that launches an illustrated guide to the shop's safety procedures

Where this has been done

- Multinational clothing retail stores in China
- Large chain tea café in China

Does not reflect McKinsey guidance customized to individual client needs - should be vetted against applicable legal and business requirements before application to a specific client

Source: Expert interviews, press search, client surveys

Limit on-site capacity

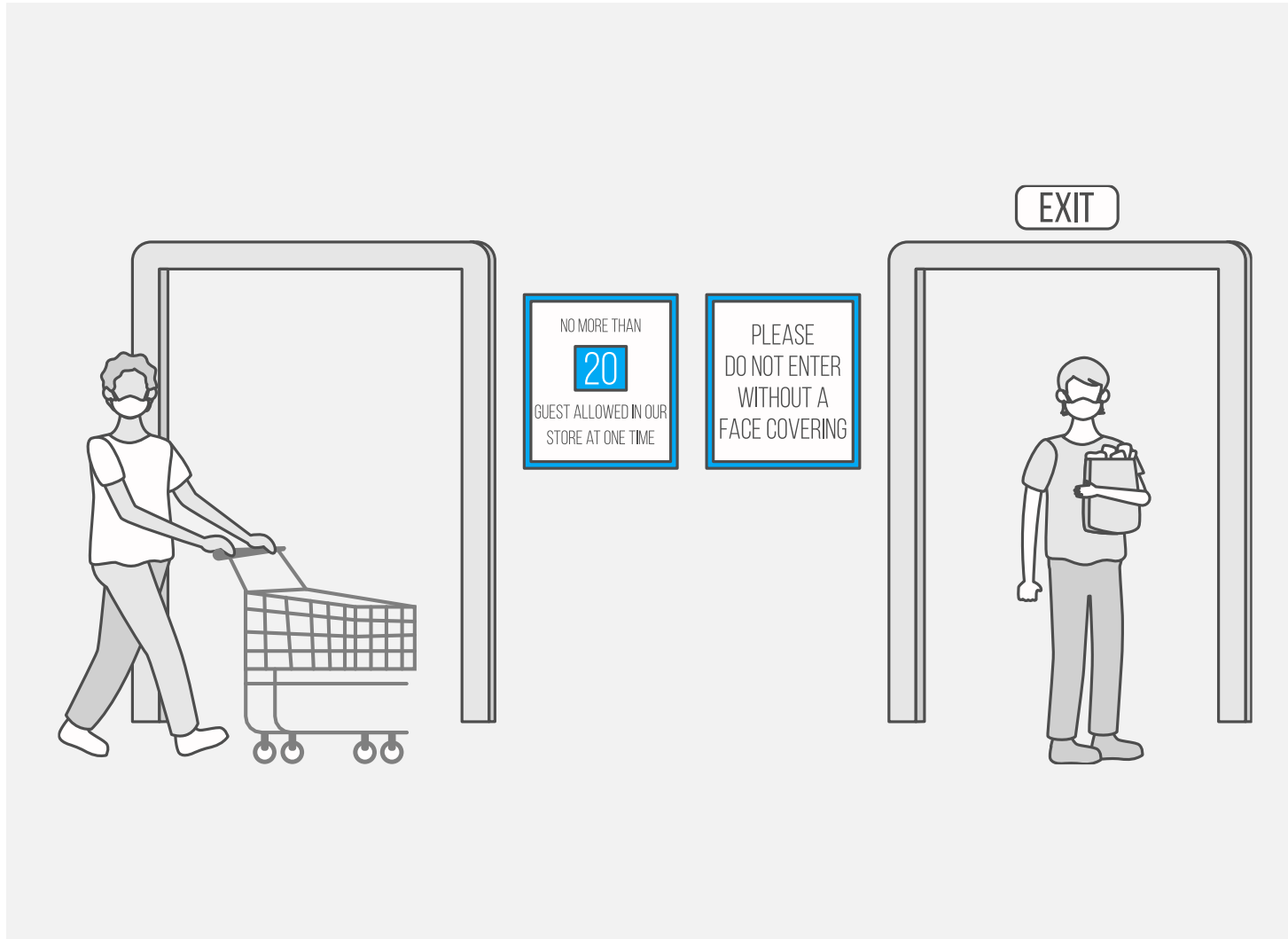

Separate in space & time

Office | Field

Description of potential intervention

Update, reduce capacities for work spaces
– for employees as well as customers

Prohibit entry for non-employees or visitors else require visitor sign ins

Restrict entry for specific zones such as production floors

Implement 1 in 1 out measures where feasible

Where this has been done

Grocery stores in the US

Corporate offices in China and S. Korea

Does not reflect McKinsey guidance customized to individual client needs - should be vetted against applicable legal and business requirements before application to a specific client

Source: Expert interviews, press search, client surveys

Restrict non-employee entry

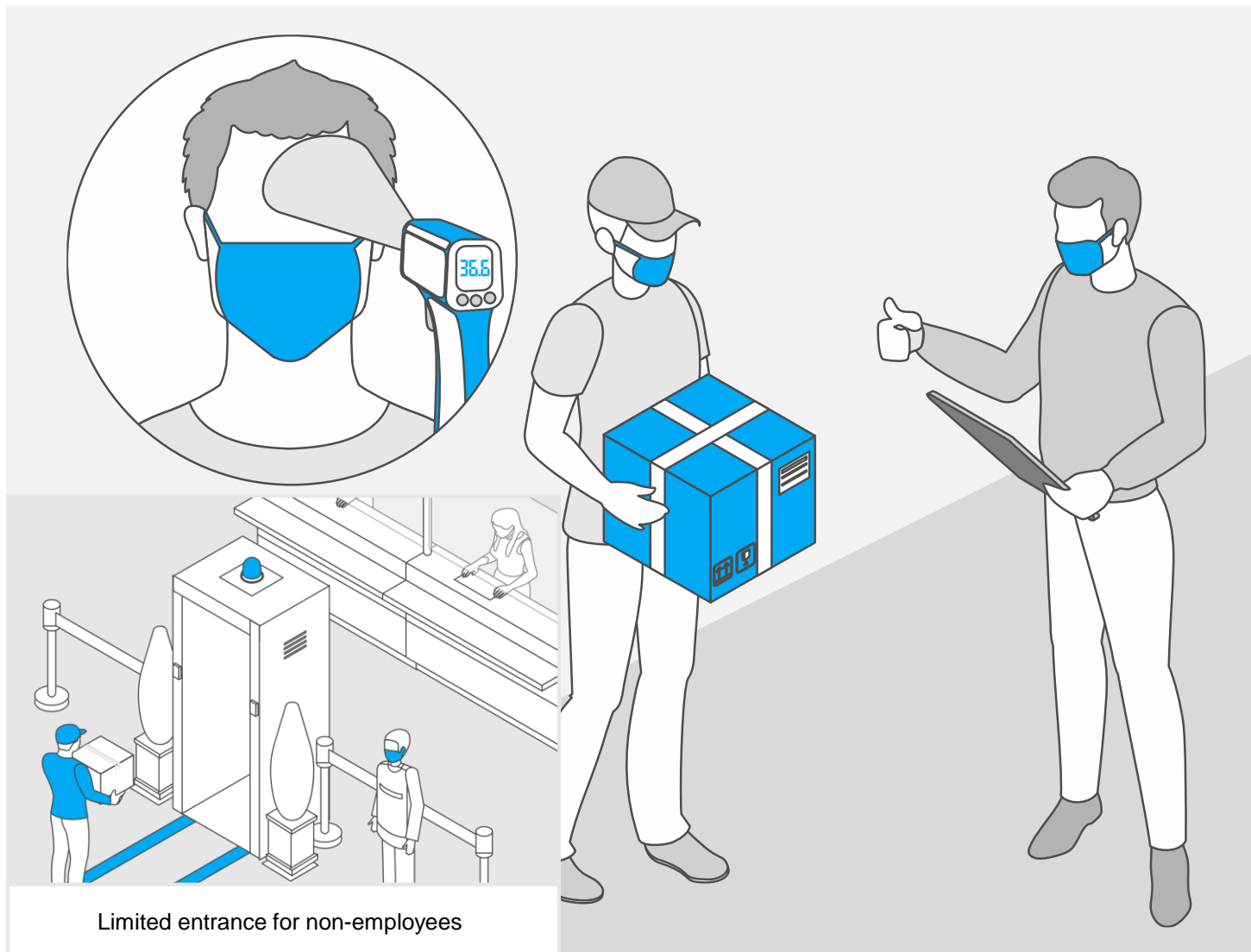

Separate in space & time

Office | Field

Description of potential intervention

Prohibit entry for visitors, non-badged contractors and non-employees except for critical activities

Screen non-badged contractors/vendors with health questionnaire and temperature check before allowing on site for deliveries, repairs, etc.,

Require pre-approval for all non-employee entrants to the office

Where this has been done

Aerospace manufacturer in China

Utilities companies, power plants and market operators in the U.s

Provide disinfectants as well as disinfected bags, carts and trolleys at entry

Clean & disinfect

Office | Field



Cleaning shopping carts



Providing hand sanitizer and disinfecting wipes

Description of potential intervention

Institute **regular cleaning of items shared by customers** (e.g., shopping carts, bags, trolleys)

Provide hand sanitizer and disinfecting wipes (for cellphone screens) before entry

Require employees or customers to leave any non-essential items in a designated storage area prior to entry

Where this has been done

Grocery stores in the US

Does not reflect McKinsey guidance customized to individual client needs - should be vetted against applicable legal and business requirements before application to a specific client

Source: Expert interviews, press search, client surveys

Separate hours for vulnerable populations

Separate in space & time

Office | Field

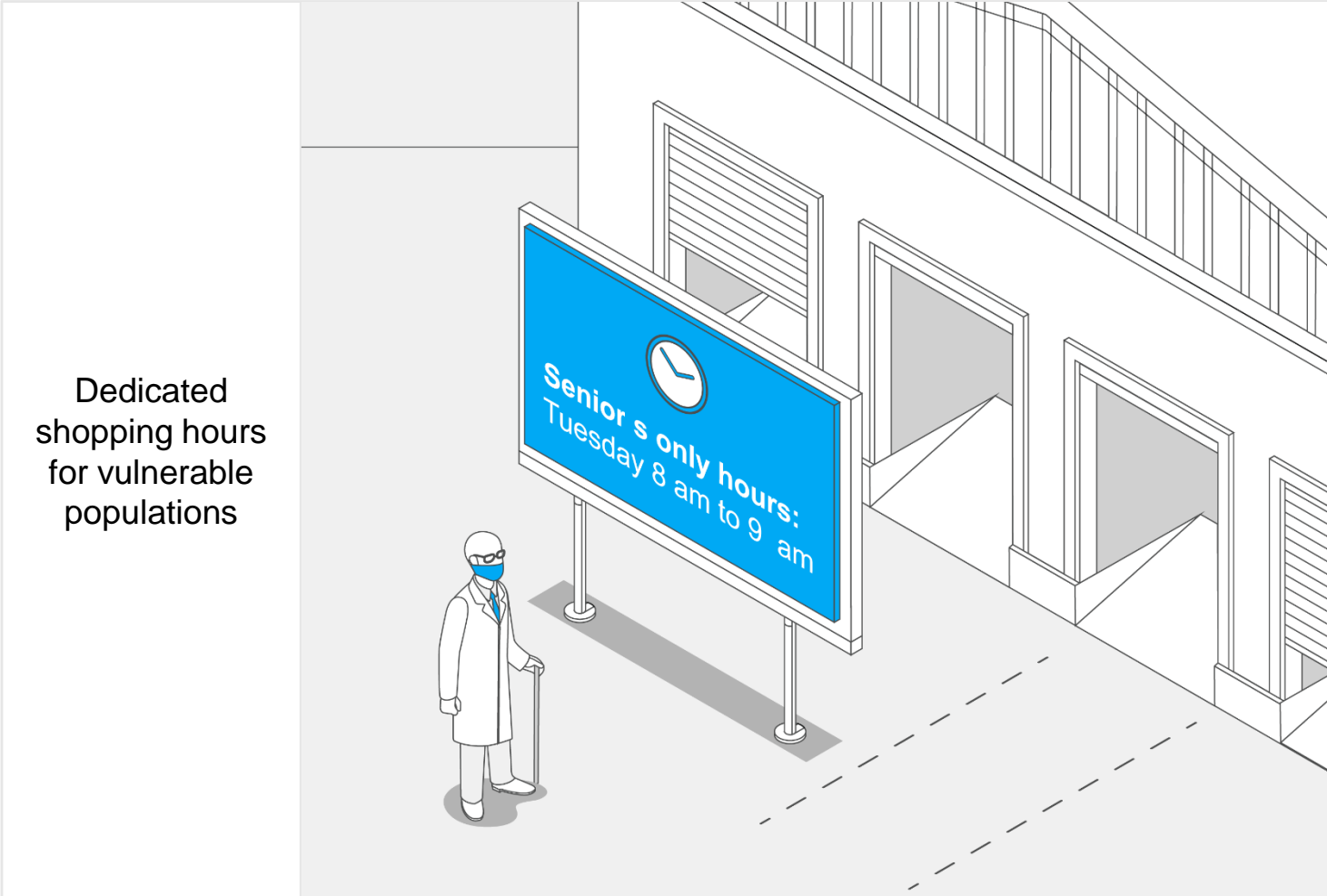

Dedicated shopping hours for vulnerable populations

Description of potential intervention

Implement **dedicated shopping hours for vulnerable groups** (elderly, persons with disabilities and pregnant women) to reduce risk of infection for at-risk persons

Extend opening times allow flexibility for vulnerable populations and to reduce density of customers in the store at a given time

Balance extra hours with time allotted for extra cleaning as well

Where this has been done

Large grocery stores in the U.S., U.K.

Does not reflect McKinsey guidance customized to individual client needs - should be vetted against applicable legal and business requirements before application to a specific client

Source: Expert interviews, press search, client surveys

Encourage or mandate appropriate PPE¹ gear (1/2)

Use protective equipment

Office | Field

PPE required or provided at entry

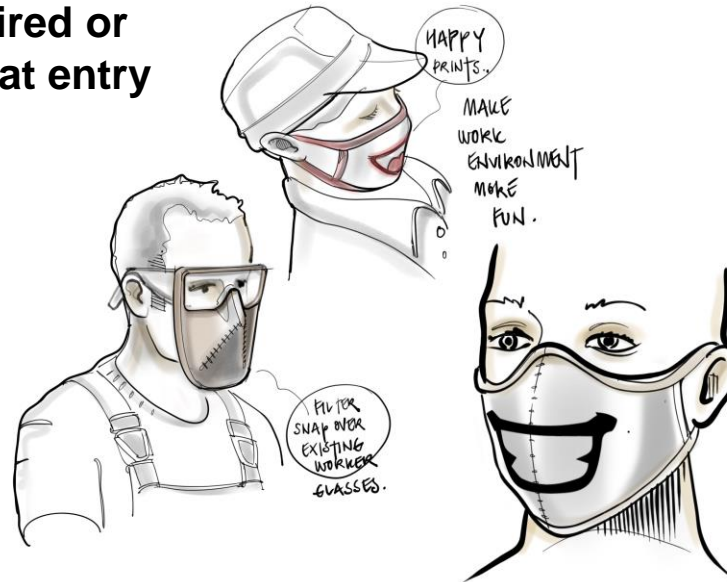

Safe working kits



1 Critical PPE (surgical masks, N-95, etc.) must continue to be reserved for healthcare workers and other medical first responders. Use should be in accordance with local government and health organization guidelines

Description of potential intervention

Forbid anyone who doesn't wear face masks from entering into company buildings

Alternatively, recommend face masks and gloves in all or specifically-designated areas of the company

Compensate employees for buying facemasks

Provide face masks (and safe working kits) to employees for free and distribute upon entry

Where this has been done

South Korean conglomerates

S. Korean multinational automotive manufacturer began preparation of mask production for its own employees













China: Multinational clothing retail brands

Does not reflect McKinsey guidance customized to individual client needs - should be vetted against applicable legal and business requirements before application to a specific client

Source: Expert interviews, press search, client surveys

Encourage or mandate appropriate PPE¹ gear (2/2)

Details in Appendix

OSHA Risk Level	PPE Usage			
	Respirators and masks	Gowns	Eye protection	Gloves
 High-Very High Risk				
 Medium Risk				
 Low Risk				

1 Critical PPE (surgical masks, N-95, etc.) must continue to be reserved for healthcare workers and other medical first responders. Use should be in accordance with local government and health organization guidelines

Infrequent use of respirators and gowns in medium risk category¹

Does not reflect McKinsey guidance customized to individual client needs - should be vetted against applicable legal and business requirements before application to a specific client

Source: Expert interviews, press search, client surveys

Use protective equipment

Office | Field

Description of potential intervention

Encourage or mandate PPE usage based on work environment:

- Healthcare workers given preference for N95 respirators (use for 5-7 days) or provided 2 masks a day
- Production employees wear polyester gloves and glasses
- Office employees and customer-facing employees given daily masks (cloth masks suffice)

Where this has been done

- Aerospace and Defense manufacturer in China
- Companies in South Korea
- Clothing retail stores in China
- Grocery stores in the U.S.

Provide mental health services to employees affected by COVID-19 / quarantine

Drive safe behavior norms

Office | Field

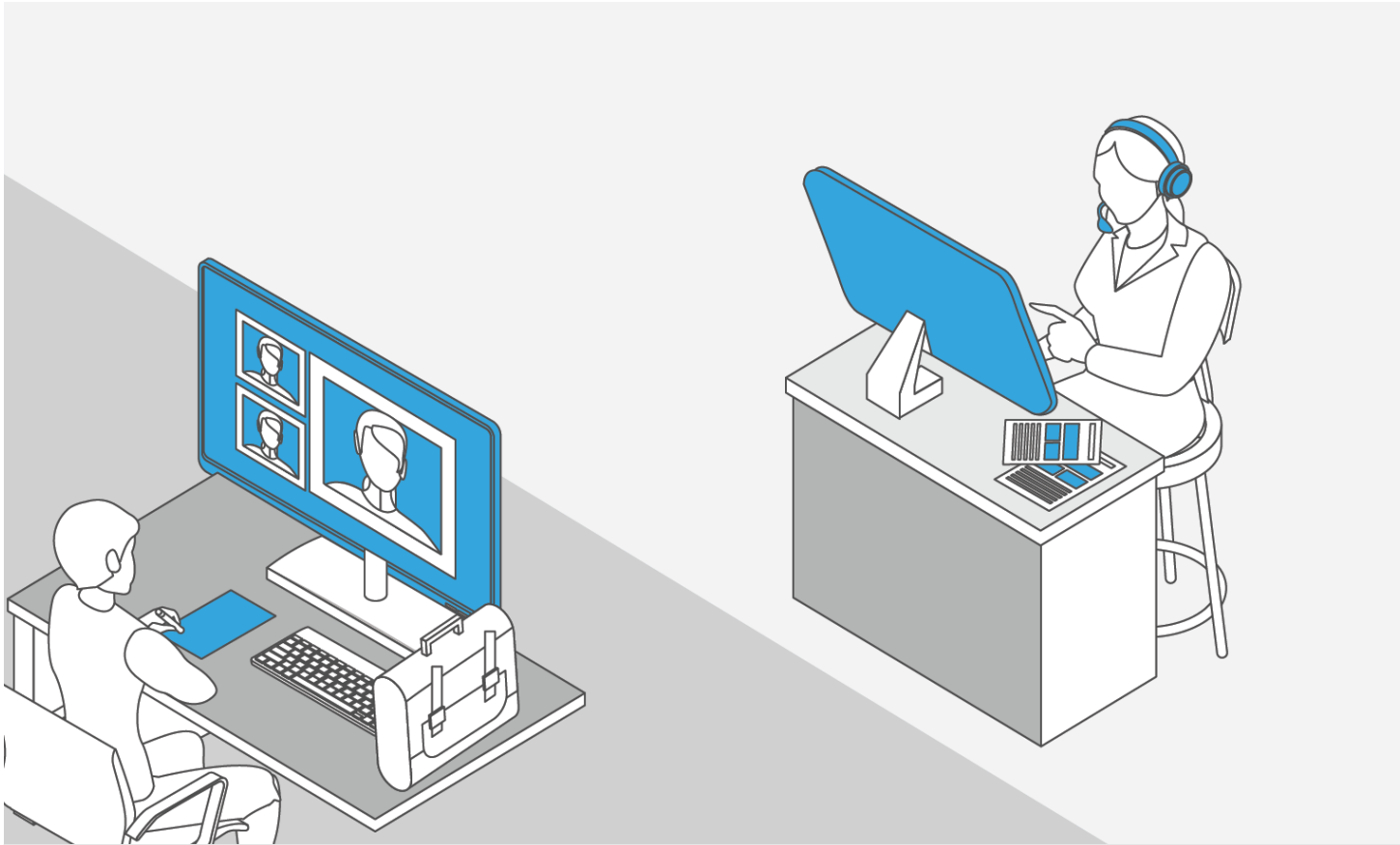

Teletherapy services as well as online support on navigating mental health resources

Description of potential intervention

Provide counselling (teletherapy) services to employees returning to work after prolonged quarantines

Expand benefit coverage of EAP programs

Hire an on-site specialist for therapy in the office place

Provide employees with free subscriptions to apps that aid with better mental health practices (eg. Guided meditations)

Where this has been done

Corporations in the U.S.

Multinational coffee house

American financial services company

Does not reflect McKinsey guidance customized to individual client needs - should be vetted against applicable legal and business requirements before application to a specific client

Source: Expert interviews, press search, client surveys

At work

Stagger work shifts between employees

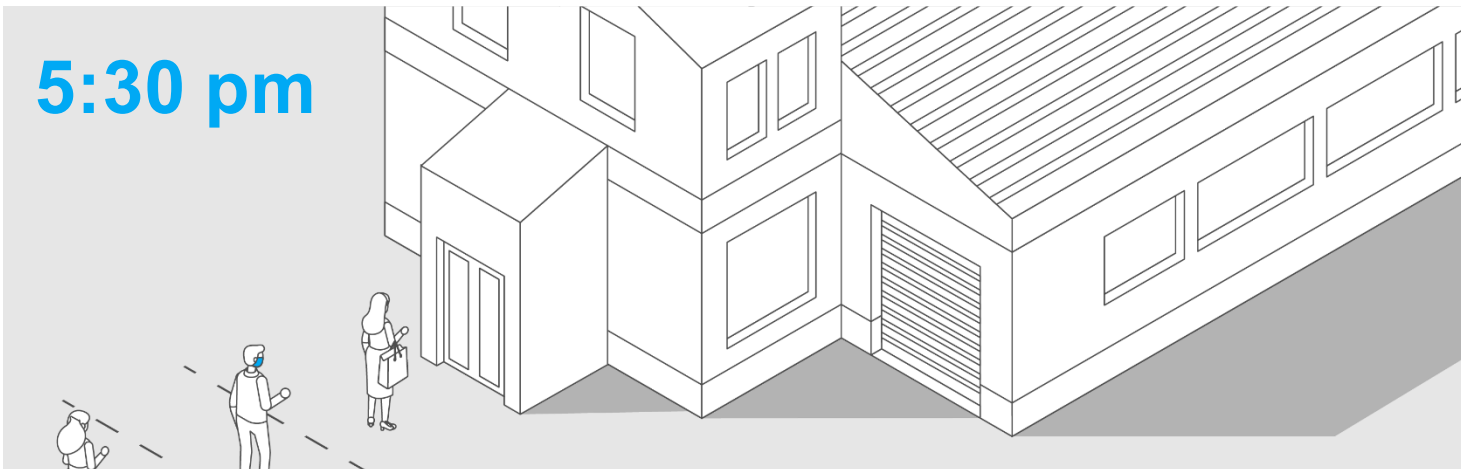

Separate in space & time

Office

Description of potential intervention

Stagger shifts / implement flexible work hours to prevent overlap between employees and improve contact tracing

Eliminate interactions across shifts:

- Use video conferencing for handoffs / transfers from one work shift to the next
- Use virtual onboarding and briefings (e.g., online conferencing services, conference calls)
- Conduct briefings in the field to reduce large meetings

Where this has been done

Aerospace and defense manufacturer in China

Does not reflect McKinsey guidance customized to individual client needs - should be vetted against applicable legal and business requirements before application to a specific client

Source: Expert interviews, press search, client surveys

Reduce operating hours to accommodate additional cleaning

Clean & disinfect

Office

Description of potential intervention

Reduce operating hours for deep-cleaning of the space and sanitization of products

Where this has been done

US grocery stores

Grocery stores around the world

Reduced operating hours so more deep cleaning can be done

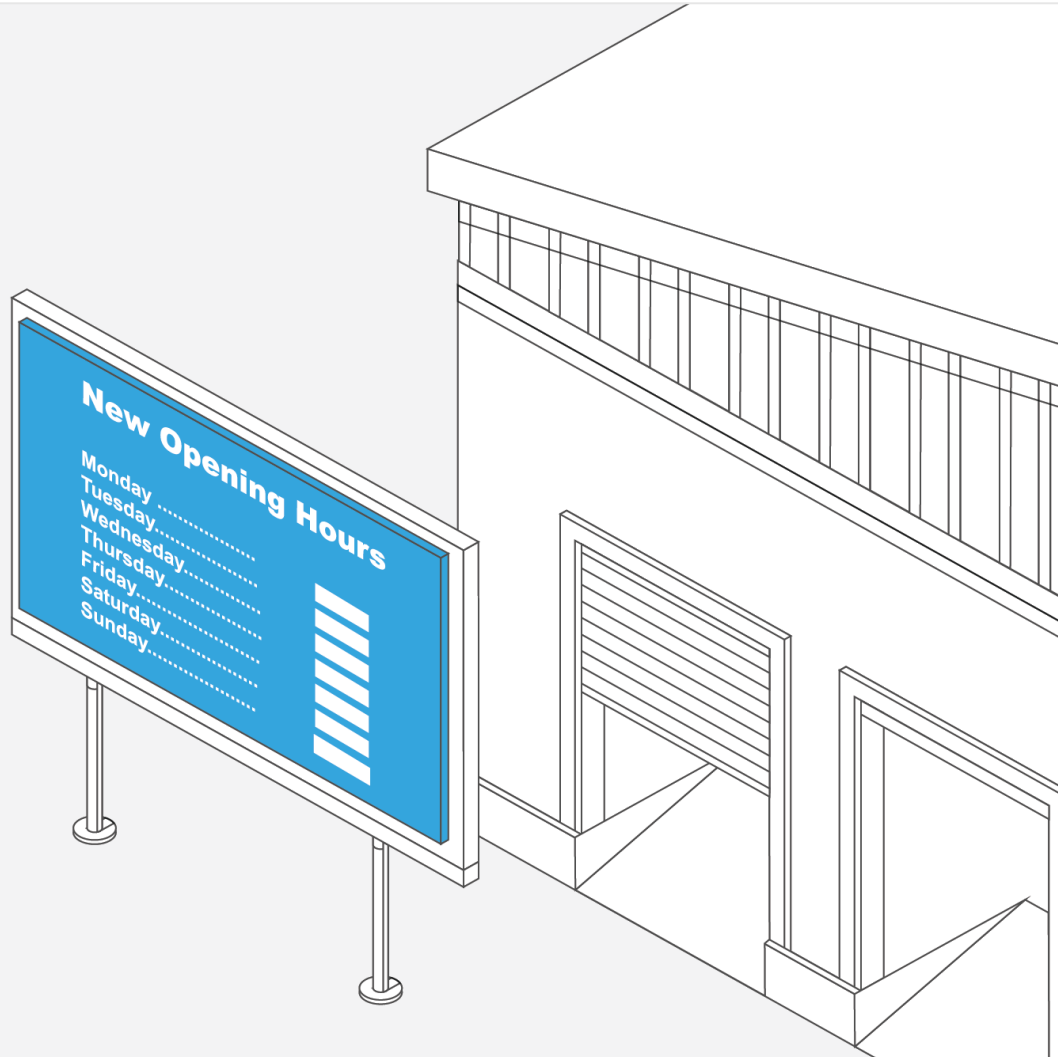

Does not reflect McKinsey guidance customized to individual client needs - should be vetted against applicable legal and business requirements before application to a specific client

Source: Expert interviews, press search, client surveys

Promote healthy personal habits with high-visibility signage and media campaigns

Increase awareness

Office

Description of potential intervention

Promote healthy habits with **high-visibility signage** across the workspace (e.g., wash hands frequently)

Leverage media and advertising to create awareness among employees and customers

Where this has been done

Corporate offices in China

Corporate offices in US (prior to full closure)

Several multinational retail brands have used advertising to promote social distancing

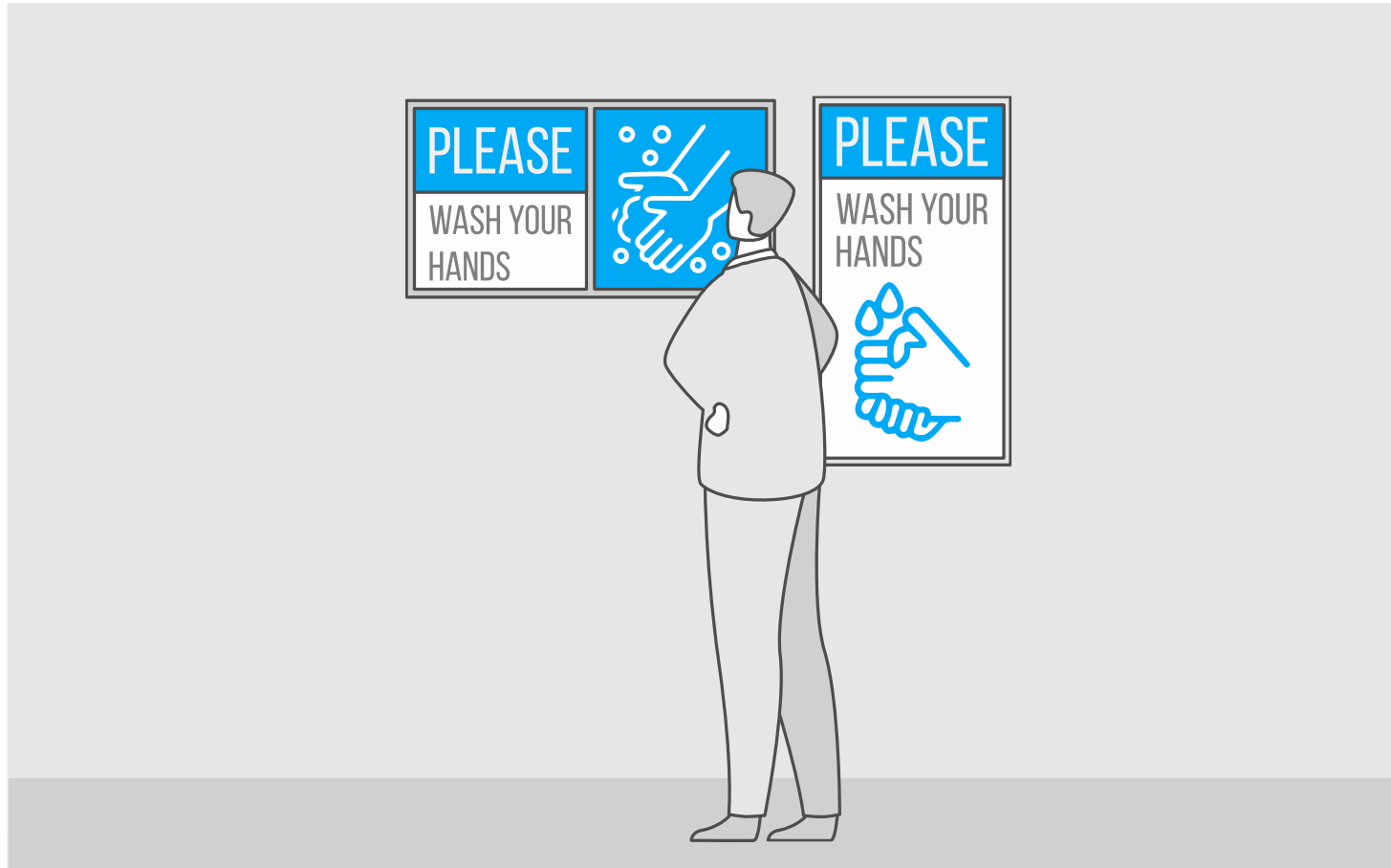

Clearly denote expected practices

Does not reflect McKinsey guidance customized to individual client needs - should be vetted against applicable legal and business requirements before application to a specific client

Source: Expert interviews, press search, client surveys

Highlight new workplace safety processes and policies through prominent displays

Increase awareness

Office

Informational materials in displays and advertising



Description of potential intervention

Display large format posters or digital displays providing prominent, frequent reminders to employees of the new workplace situation, protocols and (crucially) the rationale behind it

Where this has been done

Corporate offices in China

Does not reflect McKinsey guidance customized to individual client needs - should be vetted against applicable legal and business requirements before application to a specific client

Source: Expert interviews, press search, client surveys

Encourage or mandate appropriate PPE¹ gear (1/2)

Use protective equipment

Office | Field

PPE required or provided at entry

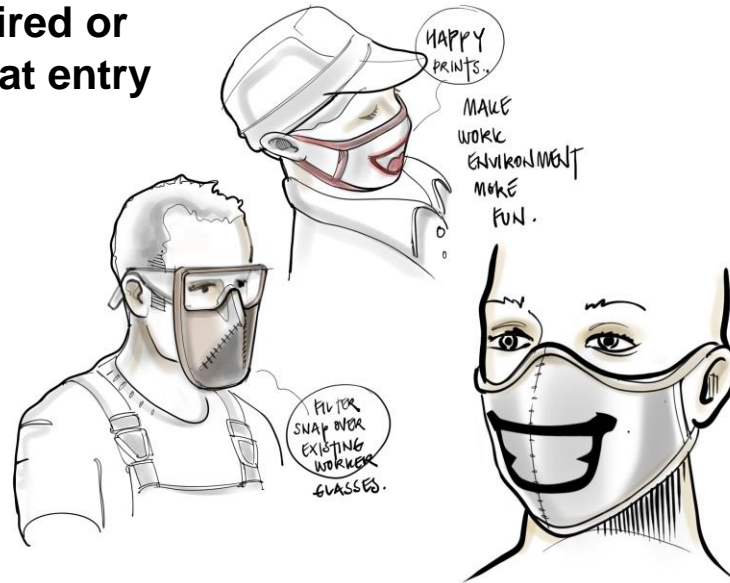

Safe working kits



1 Critical PPE (surgical masks, N-95, etc.) must continue to be reserved for healthcare workers and other medical first responders. Use should be in accordance with local government and health organization guidelines

Description of potential intervention

Forbid anyone who doesn't wear face masks from entering into company buildings

Alternatively, recommend face masks and gloves in all or specifically-designated areas of the company

Compensate employees for buying facemasks

Provide face masks (and safe working kits) to employees for free and distribute upon entry

Where this has been done

South Korean conglomerates

S. Korean multinational automotive manufacturer began preparation of mask production for its own employees













China: Multinational clothing retail brands

Does not reflect McKinsey guidance customized to individual client needs - should be vetted against applicable legal and business requirements before application to a specific client

Source: Expert interviews, press search, client surveys

Encourage or mandate appropriate PPE¹ gear (2/2)

Details in Appendix

PPE Usage				
OSHA Risk Level	Respirators and masks	Gowns	Eye protection	Gloves
 High-Very High Risk				
 Medium Risk				
 Low Risk				

1 Critical PPE (surgical masks, N-95, etc.) must continue to be reserved for healthcare workers and other medical first responders. Use should be in accordance with local government and health organization guidelines

Infrequent use of respirators and gowns in medium risk category¹

Does not reflect McKinsey guidance customized to individual client needs - should be vetted against applicable legal and business requirements before application to a specific client

Source: Expert interviews, press search, client surveys

Use protective equipment

Office | Field

Description of potential intervention

Encourage or mandate PPE usage based on work environment:

- Healthcare workers given preference for N95 respirators (use for 5-7 days) or provided 2 masks a day
- Production employees wear polyester gloves and glasses
- Office employees and customer-facing employees given daily masks (cloth masks suffice)

Where this has been done

- Aerospace and Defense manufacturer in China
- Companies in South Korea
- Clothing retail stores in China
- Grocery stores in the U.S.

Limit sharing and disinfect PPE at regular intervals

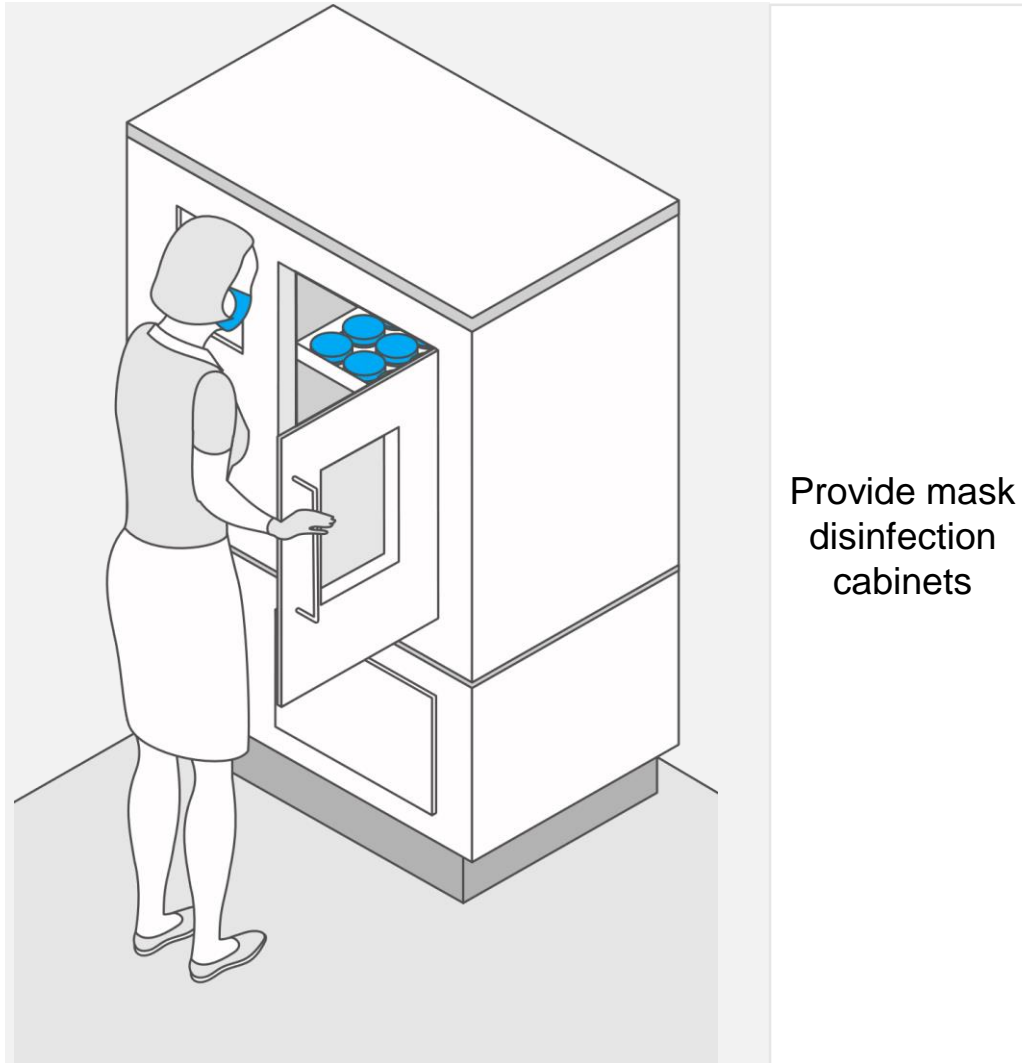

Use protective equipment

Office | Field

Description of potential intervention

Ensure protective clothing and PPE (including masks/face coverings) are not shared between employees or contractors or limit sharing to the extent possible

Disinfect employee uniforms at the end of the day

Provide mask disinfection cabinets at regular distances

Where this has been done

Multinational automotive manufacturer in China

Utilities companies in the U.S.

Power plants in the U.S.

Does not reflect McKinsey guidance customized to individual client needs - should be vetted against applicable legal and business requirements before application to a specific client

Source: Expert interviews, press search, client surveys

Ensure physical separation within the office space

Separate in space & time

Office

Separate seating arrangements

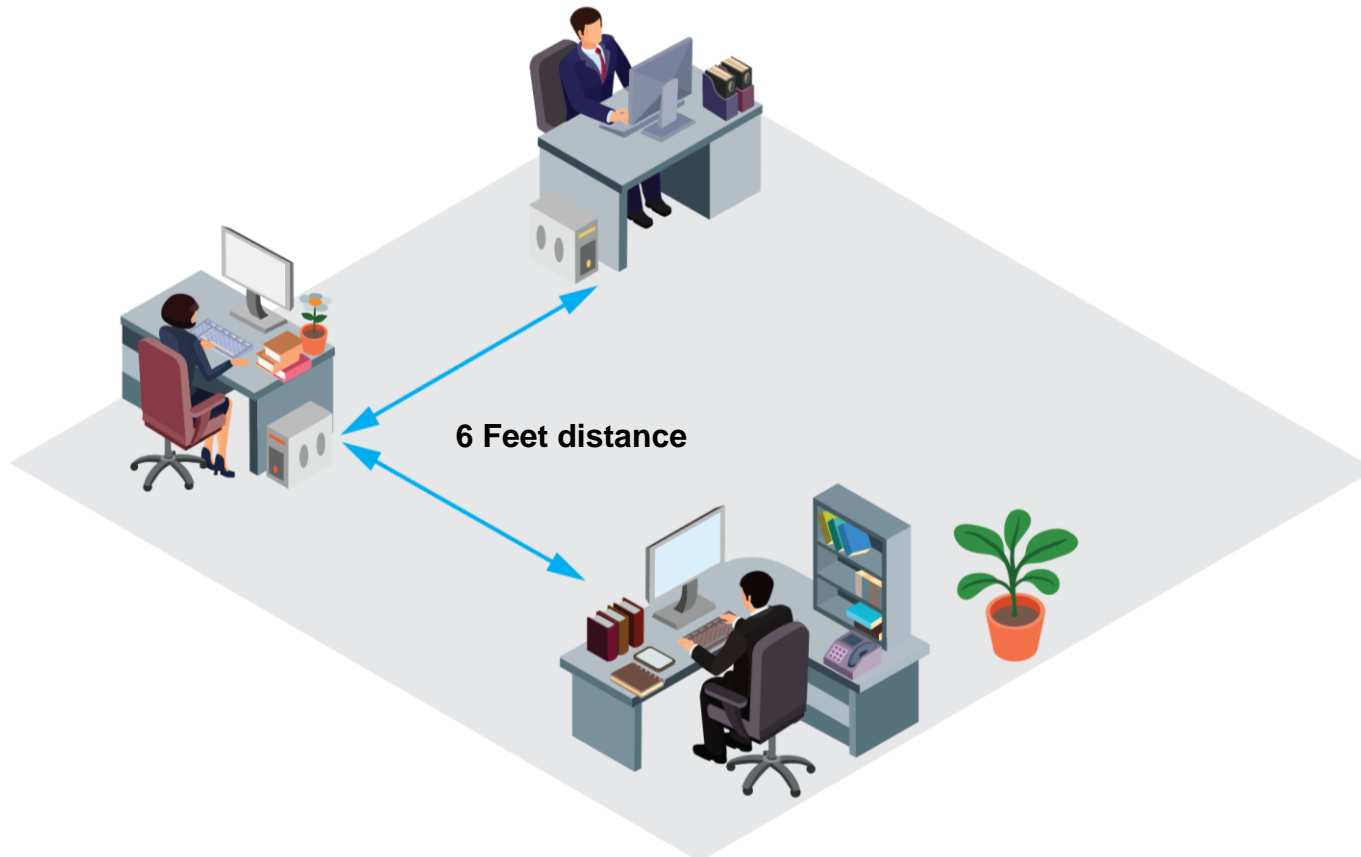

Description of potential intervention

Redo seating arrangement to reduce contact and transmission risk between employees

Allocate permanent seats and temporarily restrict free seating assignment systems

Where this has been done

Corporate offices for conglomerates in S. Korea

Does not reflect McKinsey guidance customized to individual client needs - should be vetted against applicable legal and business requirements before application to a specific client

Source: Expert interviews, press search, client surveys

Ensure physical separation through the use of zones

Clear separation of zones

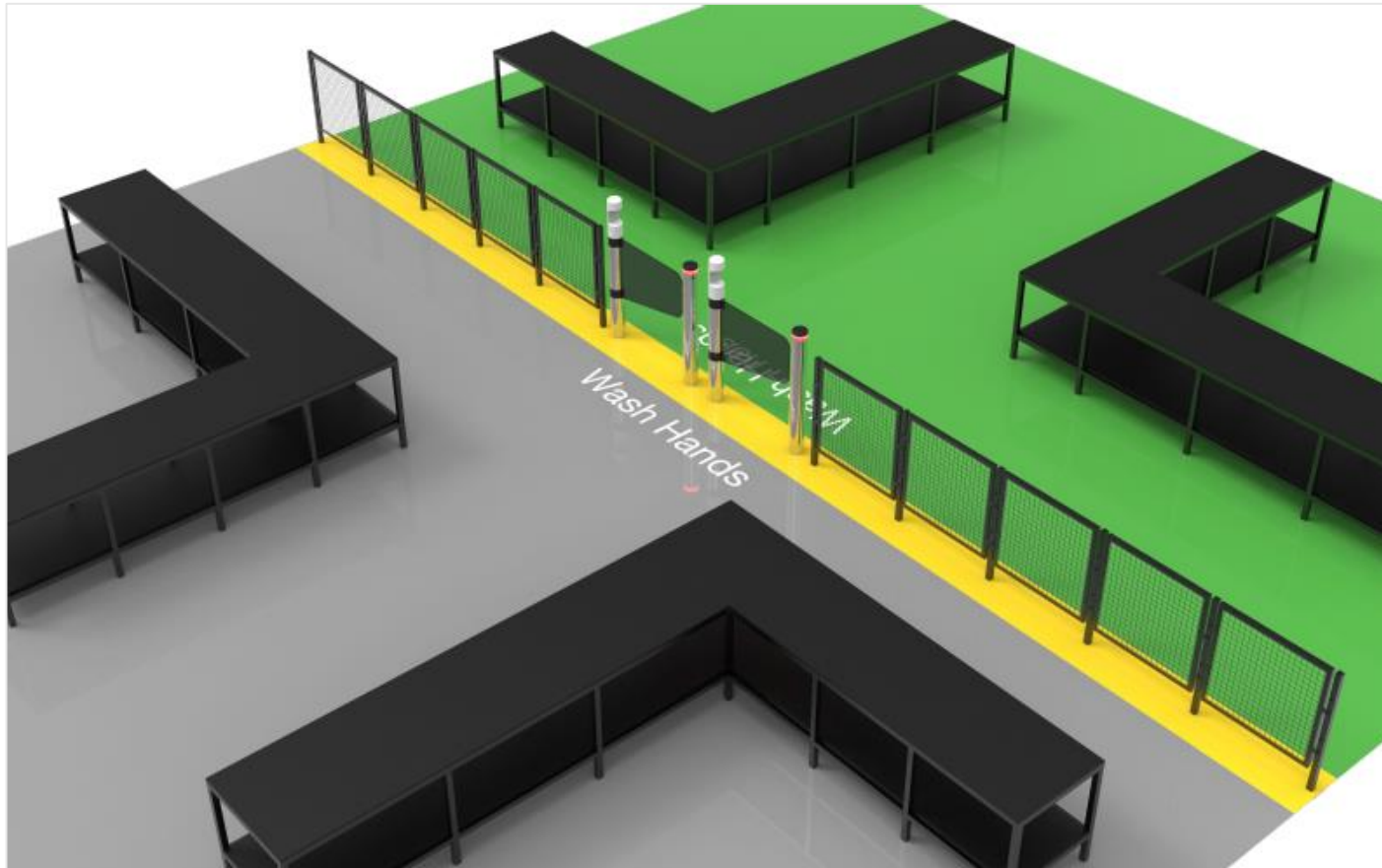

Does not reflect McKinsey guidance customized to individual client needs - should be vetted against applicable legal and business requirements before application to a specific client

Source: Expert interviews, press search, client surveys

Separate in space & time

Office

Description of potential intervention

Separate different zones in manufacturing plants, with limited movement for employees between zones

Spread employee at least (3 feet) to an extent possible on the manufacturing floor

Break up call center into zones with separate break areas, entrances and restrooms. Tape off with signage and prohibit crossing of zones without disinfection

Restrict movement through various parts of the office for staff working in that particular section

Where this has been done

Factories in China

Establish “remote-first” practices to improve culture for remote colleagues

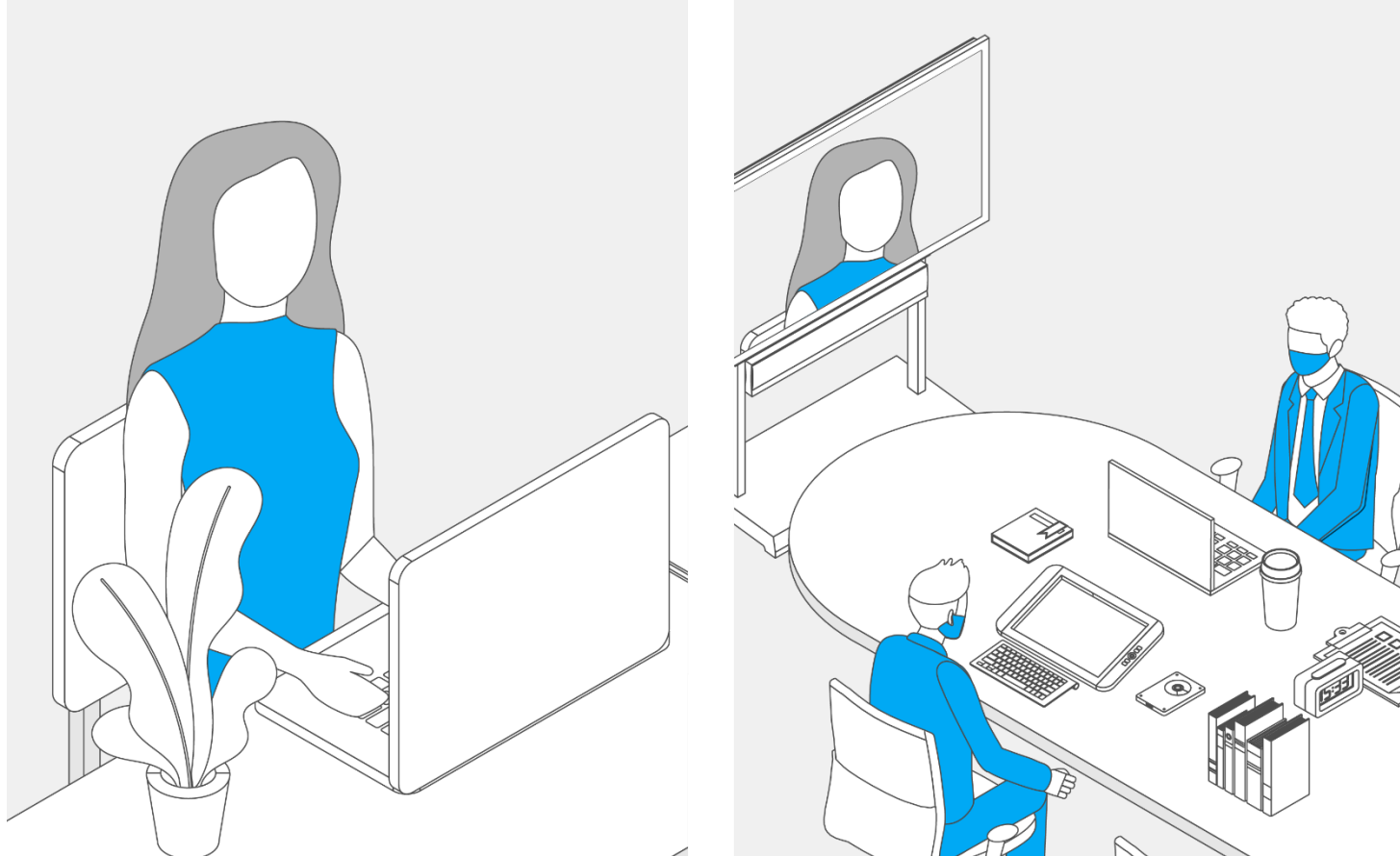

Adopt “remote-first” culture of video conferencing even when in the office

Does not reflect McKinsey guidance customized to individual client needs - should be vetted against applicable legal and business requirements before application to a specific client

Source: Expert interviews, press search, client surveys

Drive safe behavior norms

Office | Field

Description of potential intervention

Establish the **Big 5** of “remote-first” culture:

- Video conferencing by default
- Accessible, structured, and documented team meetings
- Document everything – decisions, work in progress, etc.
- No sidebar conversations (unless you document them)
- Planned together-time (e.g., offsites)

Consistently use digital tools (e.g., code management, documentation management, defect tracking, integration)

Where this has been done

Large American financial services corporation

Group employees into critical function teams, operating pods or work shifts (1/2)

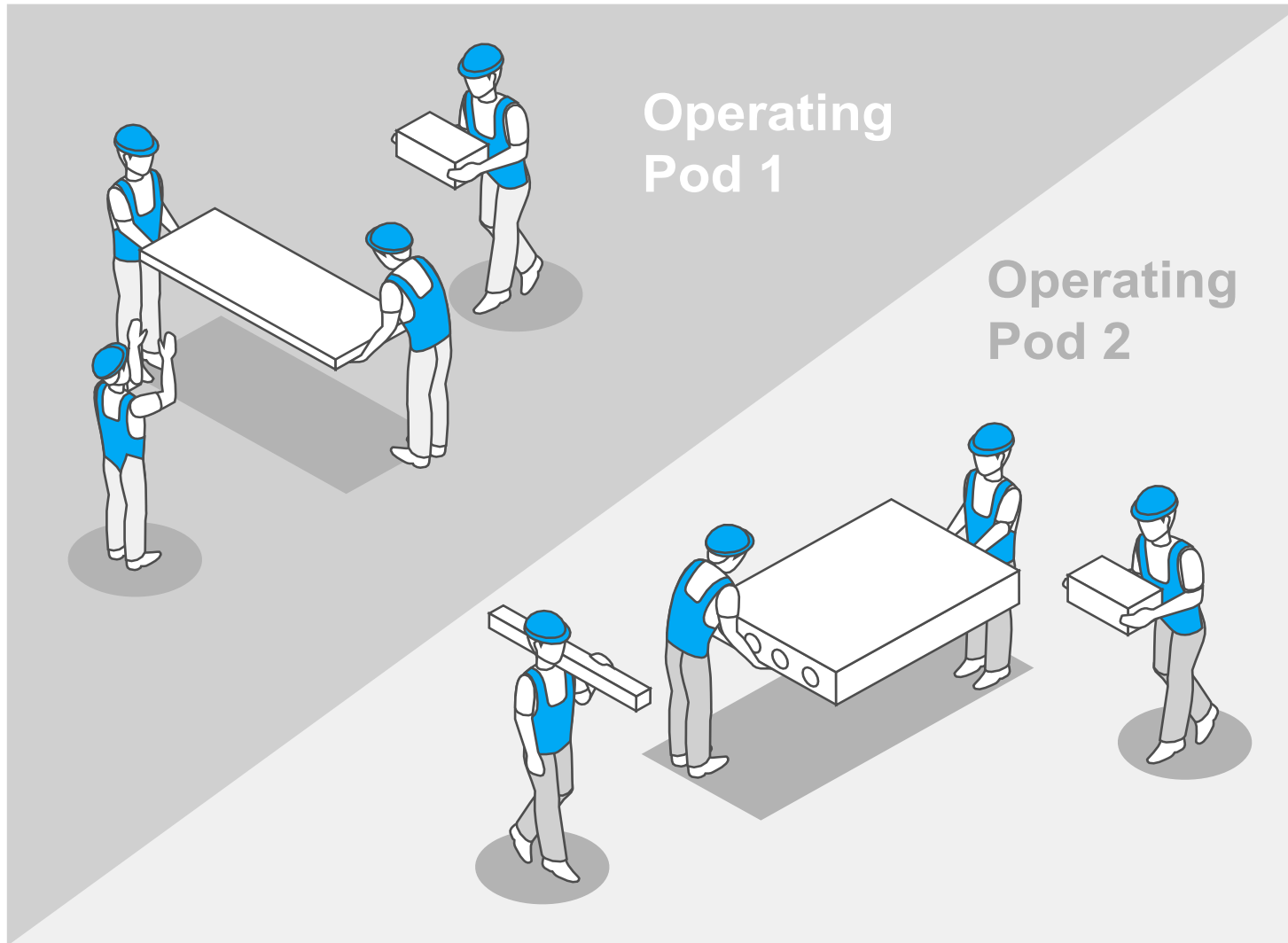

Separate in space & time

Office | Field

Description of potential intervention

Group employees into “operating pods” that stick together (work, travel, live, and eat, as applicable) to facilitate health tracking and reduce risk of infection between different pods

Divided critical function teams with groups alternating work in-office or using satellite sites

Restrict retail work shifts to the same group of employees with minimal overlap time between groups

Alter assignments for work tasks that must occur in close proximity (less than 6 feet) by pairing technicians into a “team” and do not rotate individuals with other teams

Where this has been done

Multinational electronics manufacturer in China

Does not reflect McKinsey guidance customized to individual client needs - should be vetted against applicable legal and business requirements before application to a specific client

Source: Expert interviews, press search, client surveys

Group employees into critical function teams, operating pods or work shifts (2/2)

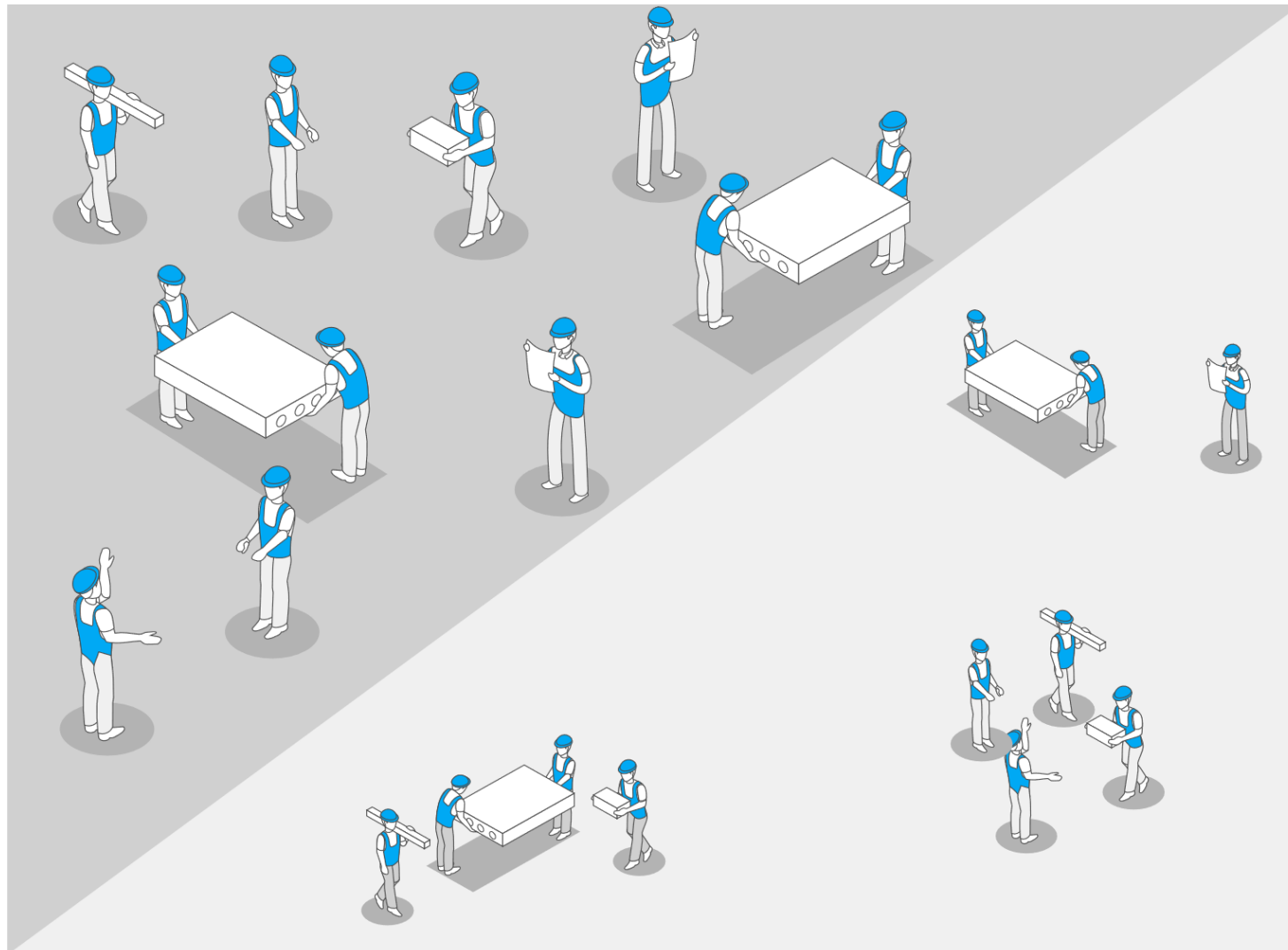

Does not reflect McKinsey guidance customized to individual client needs - should be vetted against applicable legal and business requirements before application to a specific client

Source: Expert interviews, press search, client surveys

Pre-entry

Travel to work

At Work

Common areas

Post-infection

Separate in space & time

Office | Field

Description of potential intervention

Shift to **multiple, smaller staging sites** instead of concentrated, larger staging sites to limit contact-with / exposure-to larger crews

Design smaller staging sites to **allow CDC distancing** recommendations to be followed (currently 6 feet of distancing at all times)

Where this has been done

Factories in China have used partitions to split projects into smaller groups

Provide cleaning equipment to employees and customers

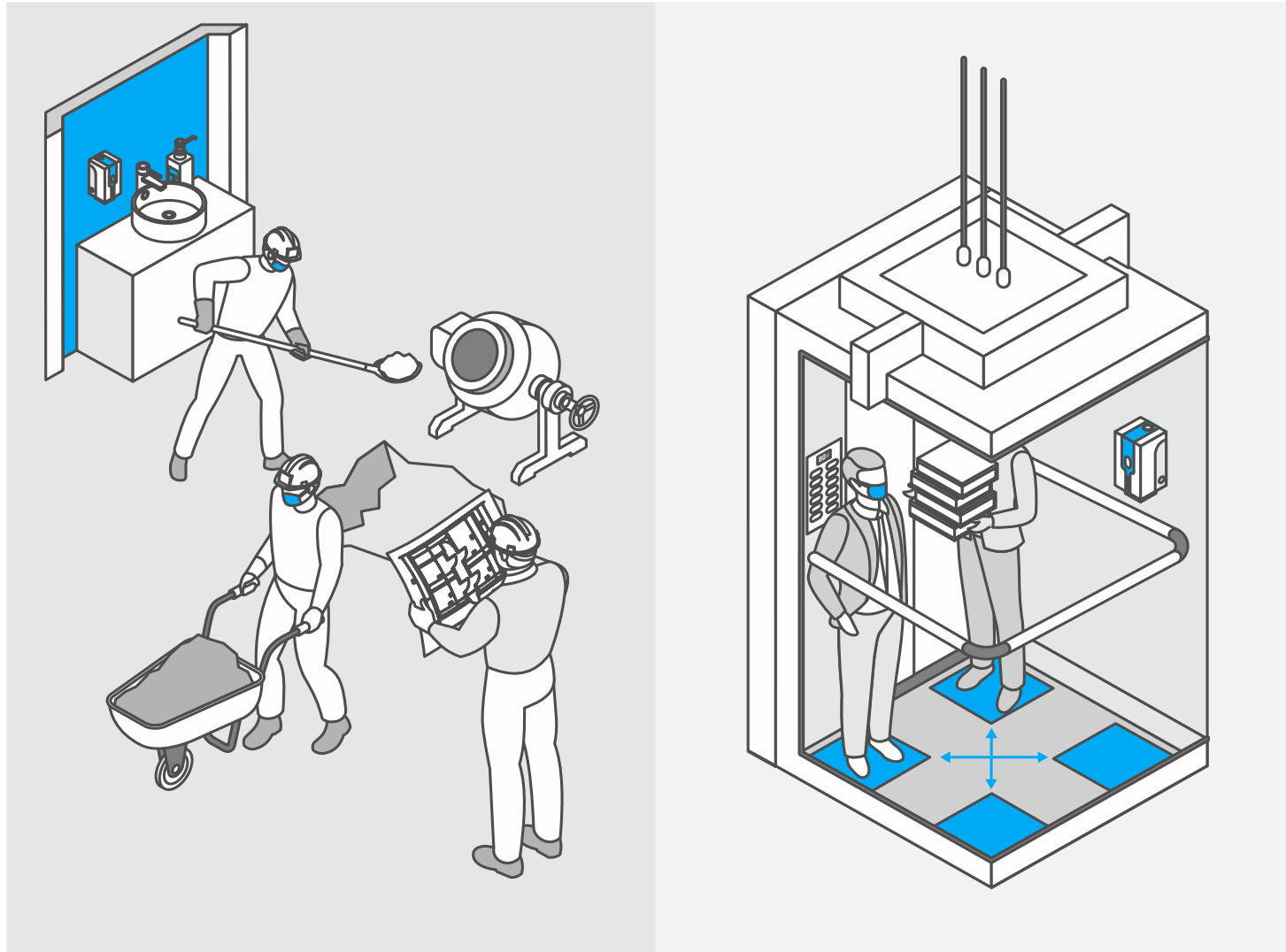

Clean & disinfect

Office | Field

Description of potential intervention

Provide cleaning supplies, hand sanitizer, and sanitation supplies, for all crews located at staging areas

Installation of **hand sanitizer dispensers** throughout building

Disinfecting wipes available in neighborhoods and meeting rooms

UV light cell phone disinfectants available in both lobbies

Where this has been done

Corporate offices and manufacturing plants worldwide

Does not reflect McKinsey guidance customized to individual client needs - should be vetted against applicable legal and business requirements before application to a specific client

Source: Expert interviews, press search, client surveys

Implement one-way store aisles with fewer sales specialists

Pre-entry

Travel to work

At Work

Common areas

Post-infection

Separate in space & time

Office | Field

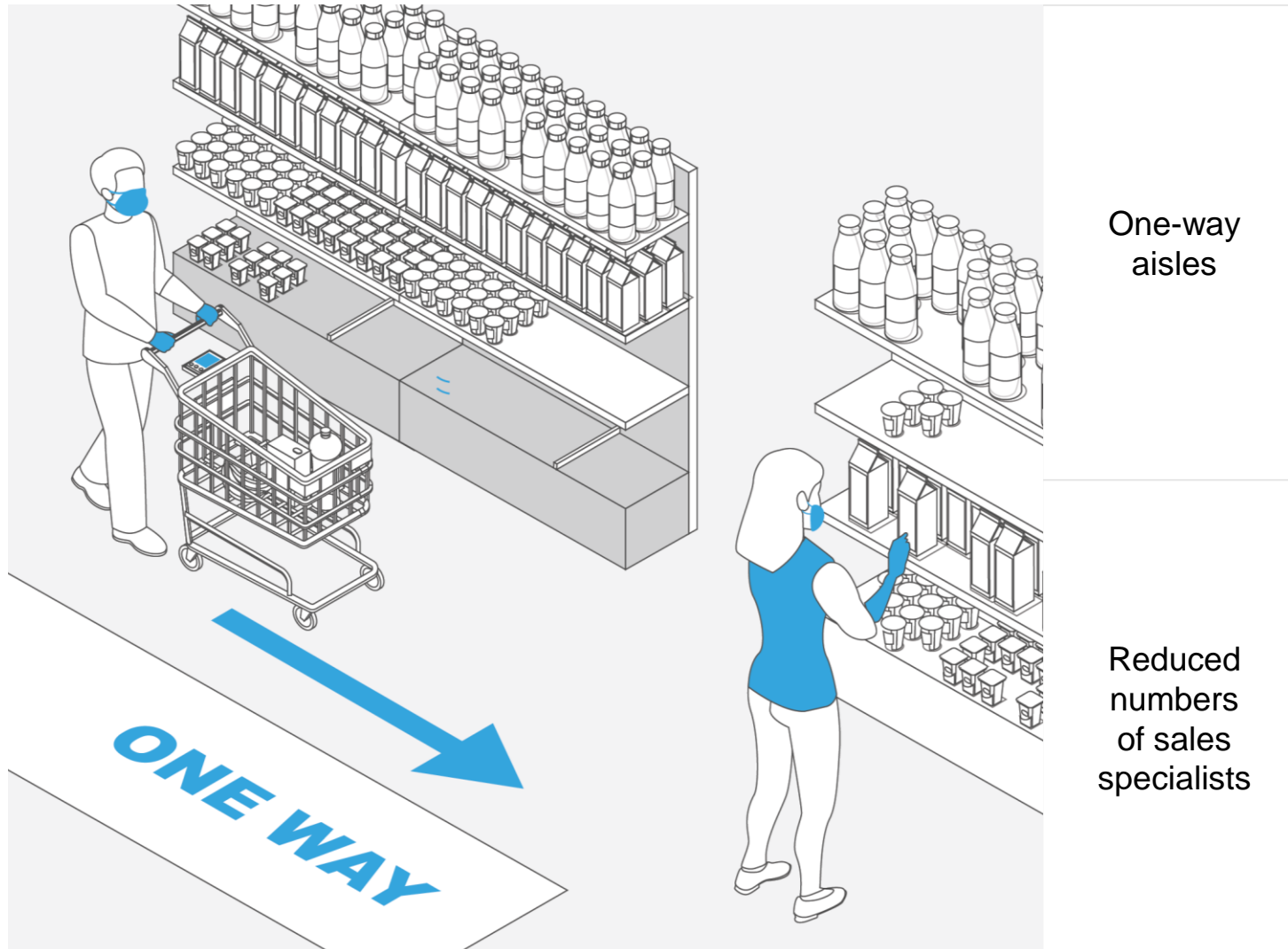

Description of potential intervention

Implement **one-way aisles in stores** to reduce density of traffic and unnecessary interactions

Reduce the number of sales specialists on the floor to decrease congestion and transmission risk

Where this has been done

Grocery stores in China/U.S.

Does not reflect McKinsey guidance customized to individual client needs - should be vetted against applicable legal and business requirements before application to a specific client

Source: Expert interviews, press search, client surveys

Reduce in-store services with high contact

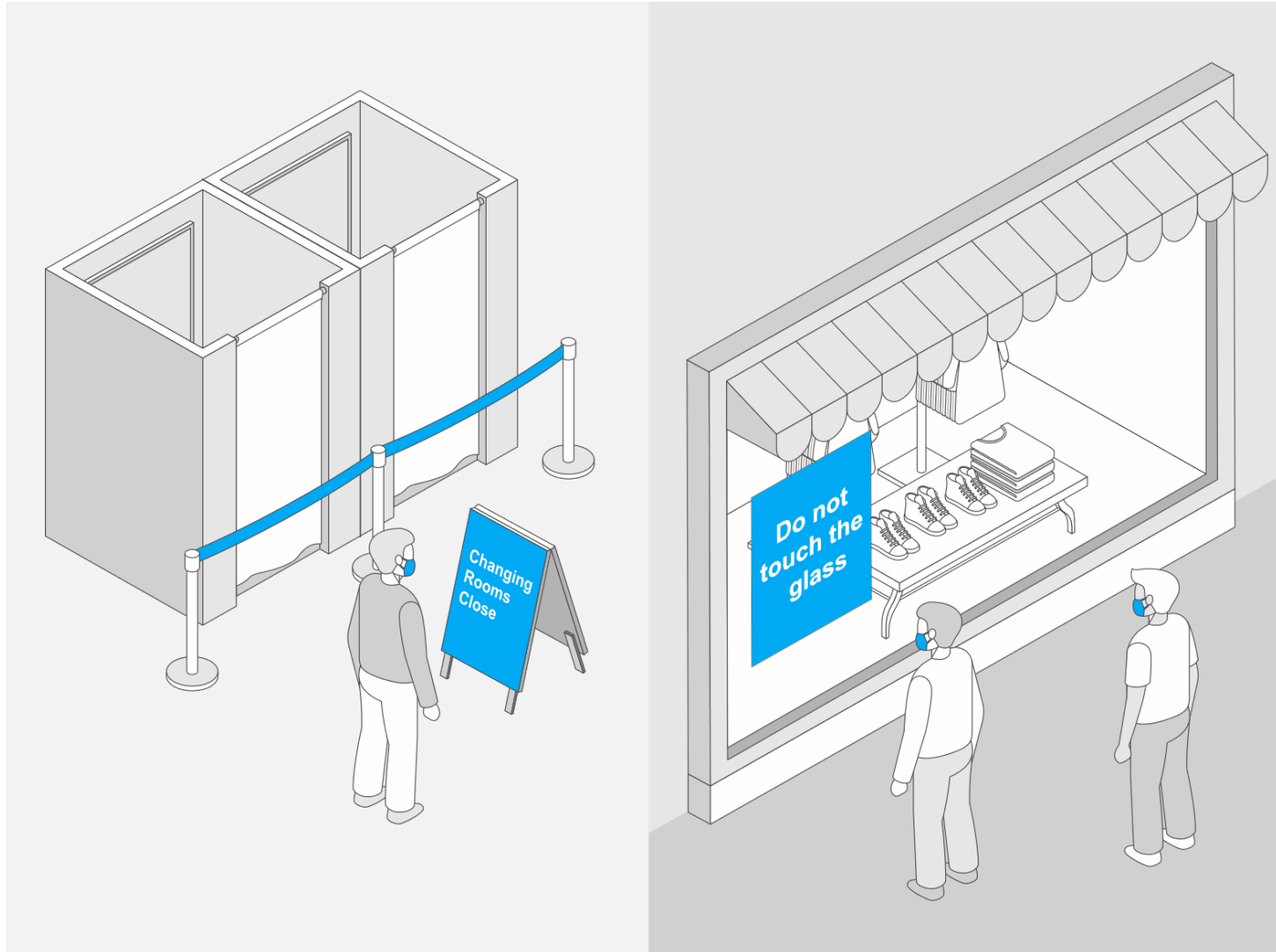

Drive safe behavior norms

Office | Field

Description of potential intervention

Eliminate in-store food samples in grocery stores / restaurants

Discourage touching of merchandise / trying on of clothes (e.g., signs to not touch glass, close changing rooms)

Disinfect test products after each demo

Encourage customers not to return items to shelves

Where this has been done

Large US supermarkets

Multinational clothing-retailers

Does not reflect McKinsey guidance customized to individual client needs - should be vetted against applicable legal and business requirements before application to a specific client

Source: Expert interviews, press search, client surveys

Ensure physical separation between customers

Separate in space & time

Office | Field

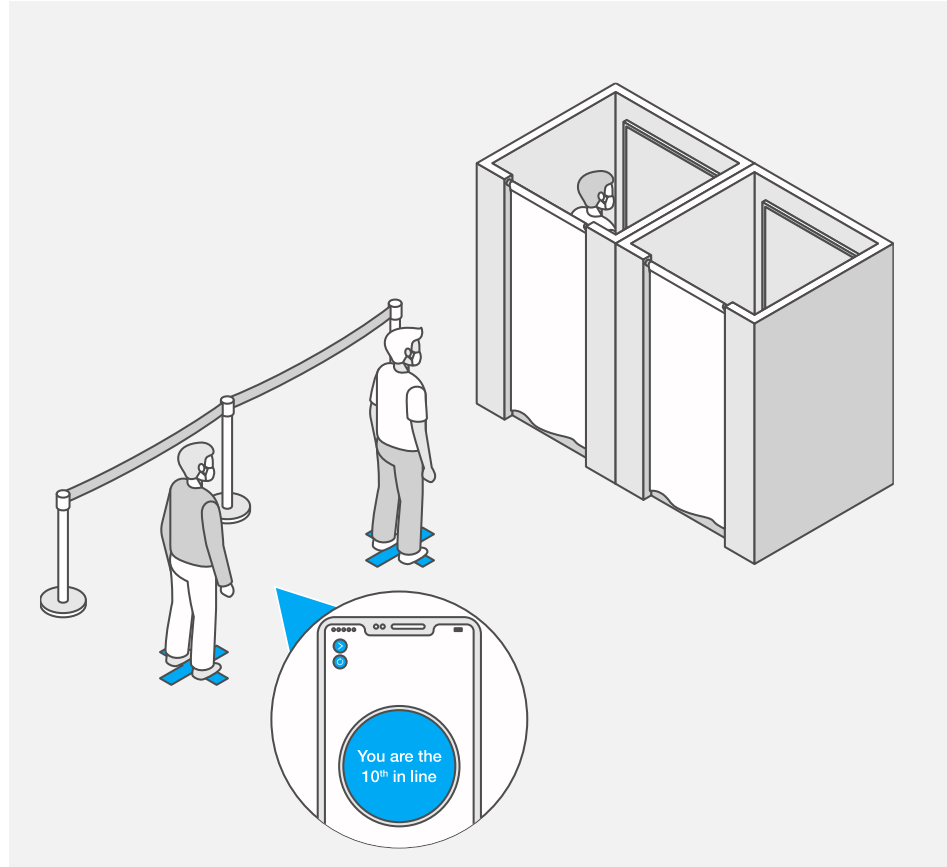

Queue for fitting room



Spacing between employees and customers

Description of potential intervention

Require distance of at least 6 feet between shoppers

Space out customer queues for fitting rooms and at cashiers with floor markers

Adopt virtual waiting area / queue and use online appointment scheduling where feasible

Where this has been done

Grocery stores in the U.S.

Multinational retail stores in China

Does not reflect McKinsey guidance customized to individual client needs - should be vetted against applicable legal and business requirements before application to a specific client

Source: Expert interviews, press search, client surveys

Have contactless thermometers visibly available onsite

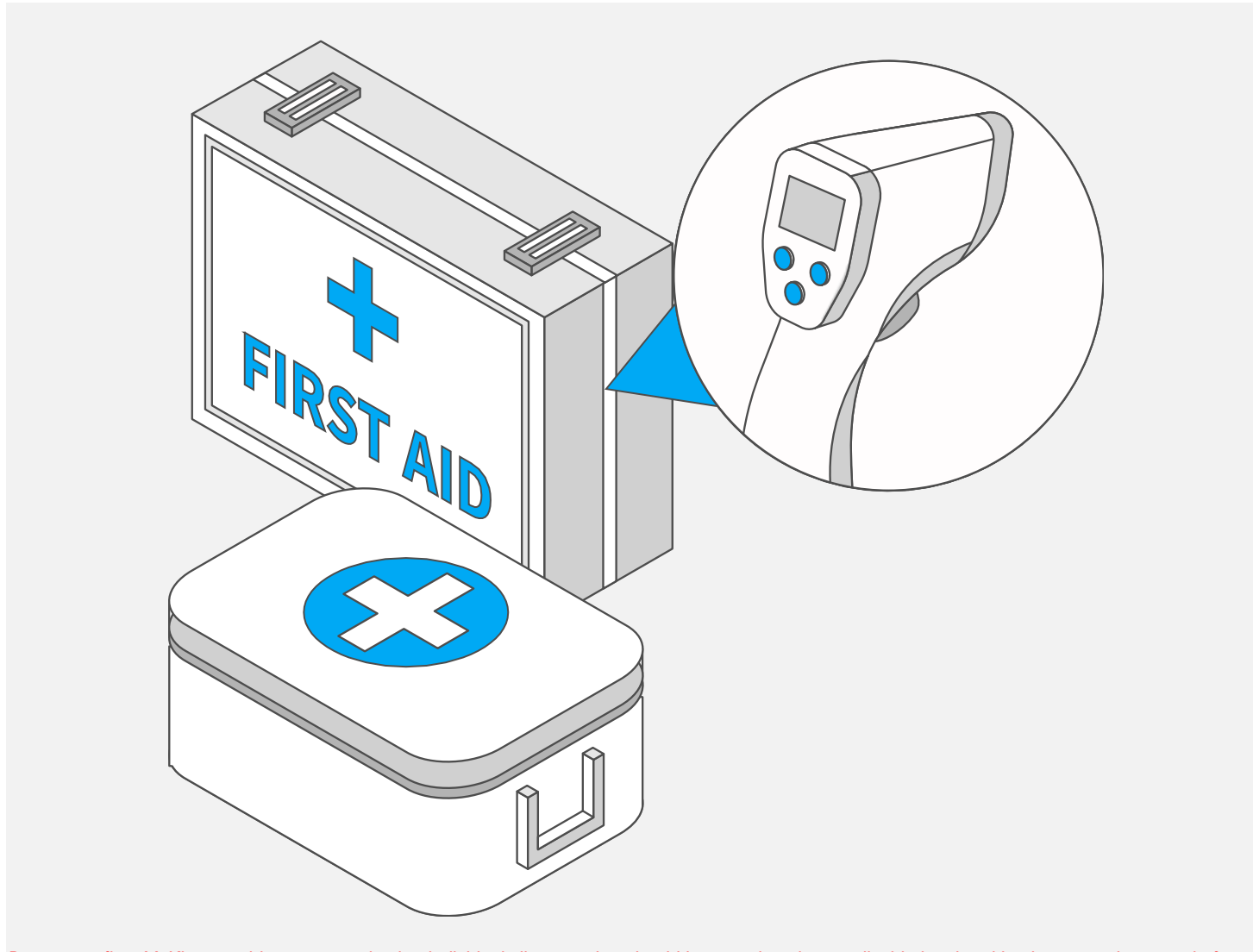

Does not reflect McKinsey guidance customized to individual client needs - should be vetted against applicable legal and business requirements before application to a specific client

Source: Expert interviews, press search, client surveys

Pre-entry

Travel to work

At Work

Common areas

Post-infection

Upgrade equipment

Office | Field

Description of potential intervention

Include contactless thermometers in all offices and worksites (e.g., in first aid kits) to encourage safe, opt-in temperature testing through the day

Where this has been done

Global corporate offices of large fast food chain

Minimize person-to-person contact for material distribution

Pre-entry

Travel to work

At Work

Common areas

Post-infection

Separate in space & time

Office | Field

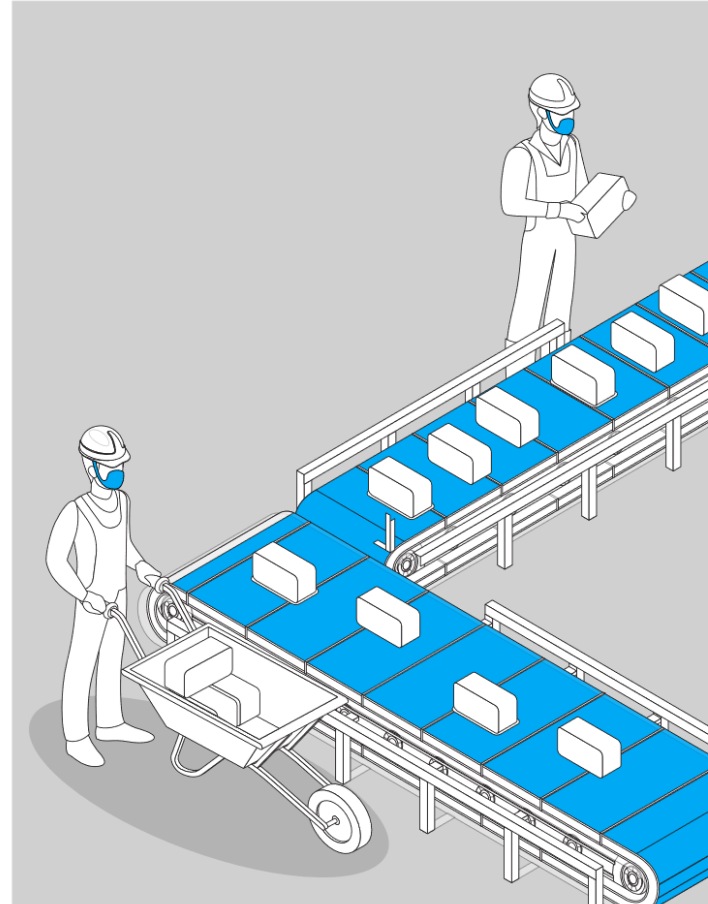
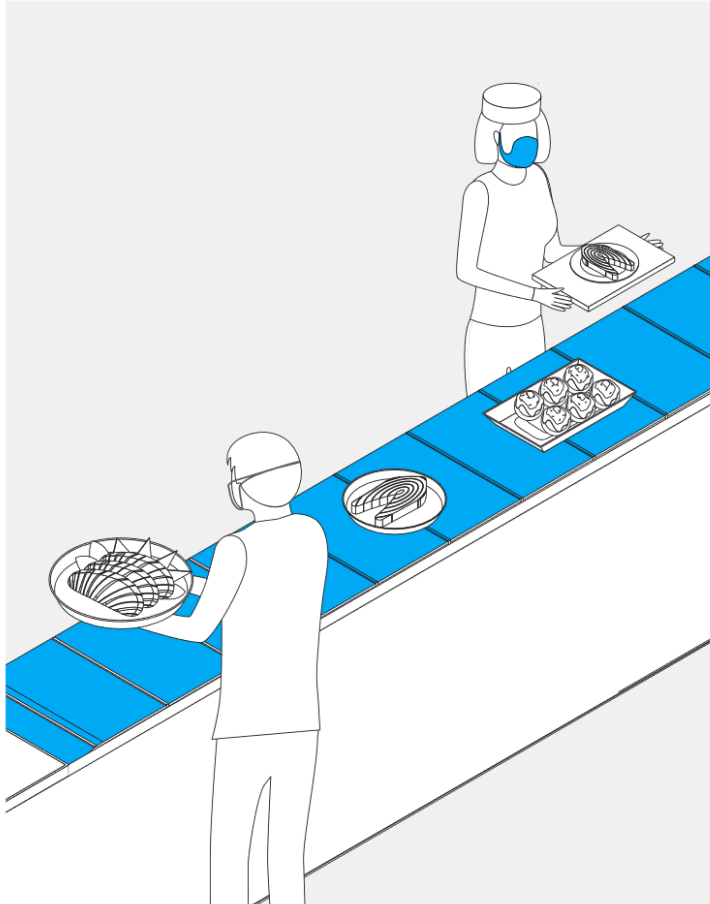

Description of potential intervention

Minimize person-to-person contact for material distribution by **using drop points**

Increase **use of conveyer belts for material distribution** such as for material deliveries on factory floors

Use small slides and conveyer belts for food transfer between employees and customers

Where this has been done

Restaurants in China

Utilities companies in the U.S.

Manufacturing factories in China

Does not reflect McKinsey guidance customized to individual client needs - should be vetted against applicable legal and business requirements before application to a specific client

Source: Expert interviews, press search, client surveys

Institute a clean desk/ work station policy for all employees

Drive safe behavior norms

Office

Description of potential intervention

Institute a clean desk policy to support overall office health and safety with daily cleaning and disinfection after the work day

Where this has been done

Global corporate offices of large fast food chain



Does not reflect McKinsey guidance customized to individual client needs - should be vetted against applicable legal and business requirements before application to a specific client

Source: Expert interviews, press search, client surveys

Limit larger gatherings/ meetings of employees

Encourage
video/audio
calls



Repurpose
conference
rooms



Does not reflect McKinsey guidance customized to individual client needs - should be vetted against applicable legal and business requirements before application to a specific client

Source: Expert interviews, press search, client surveys

Drive safe behavior norms

Office | Field

Description of potential intervention

Limit in-person gatherings to no more than 2 people to a room

Cancel non-business-critical, in-person activities (e.g., happy hours, community service)

Hold necessary group meetings (e.g., Town Hall, Steering Committee, Board meetings) **via Video Conference** wherever possible (even if employees are in the office)

Where this has been done

American multinational companies

Corporate offices in South Korea

Move in-person processes to digital



Does not reflect McKinsey guidance customized to individual client needs - should be vetted against applicable legal and business requirements before application to a specific client

Source: Expert interviews, press search, client surveys

Drive safe behavior norms

Office | Field

Description of potential intervention

Move **paper-based / in-person processes to digital forms** (e.g., various construction forms, check-lists, maps, timesheets)

Where this has been done

- Retail multinationals digitizing sales process
- Corporate offices digitizing badging-in / sign-in process
- Hotel chains and retailers in North America
- Utilities companies in the U.S.

Encourage frequent and staggered sanitization breaks for all employees

Clean & disinfect

Office | Field

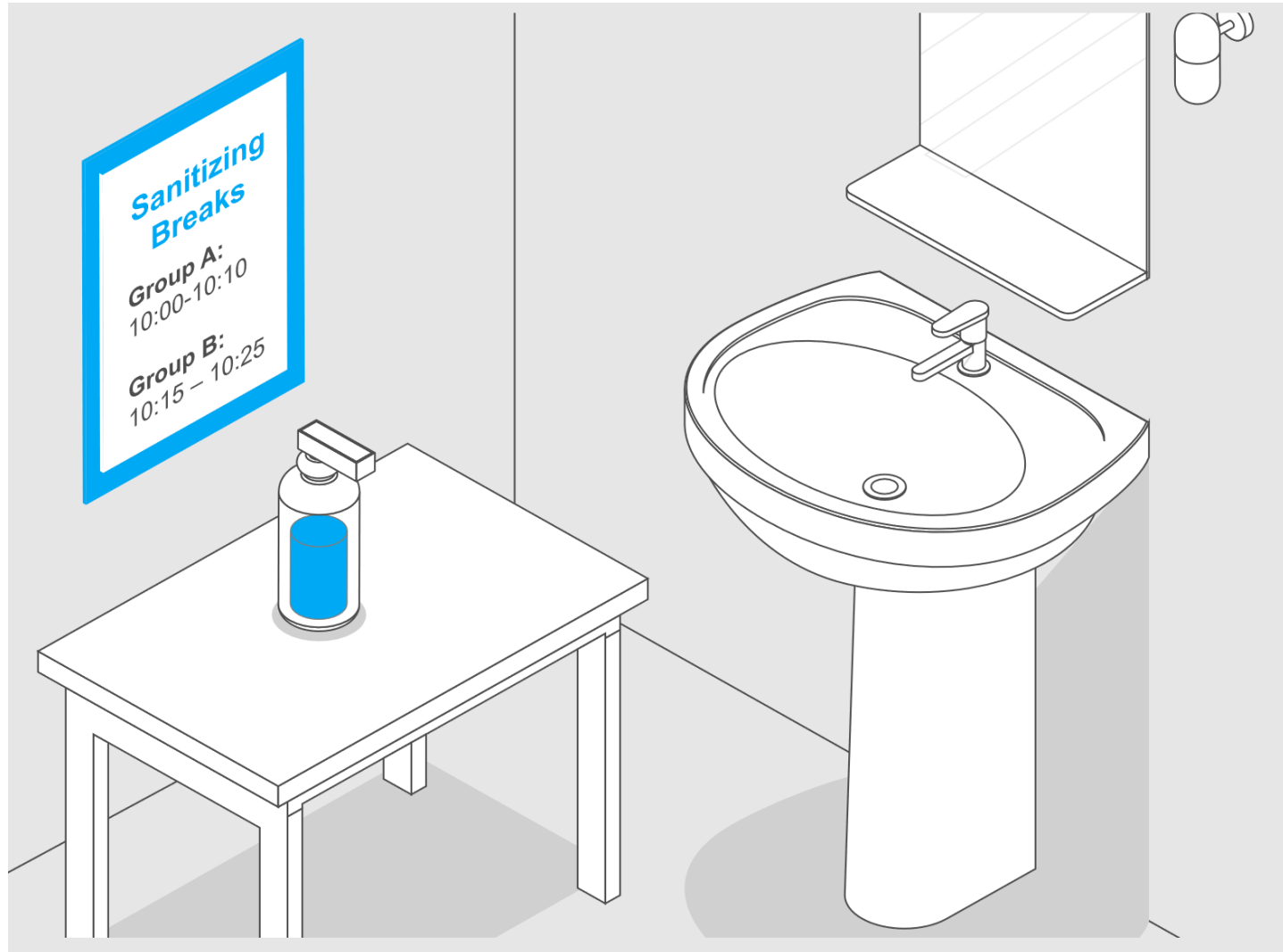

Description of potential intervention

Have opt-in, staggered hand washing breaks to allow for frequent cleaning without causing congestions

Encourage use of alcohol-based hand sanitizer at certain time intervals

Where this has been done

Corporate offices and manufacturing plants in China

Does not reflect McKinsey guidance customized to individual client needs - should be vetted against applicable legal and business requirements before application to a specific client

Source: Expert interviews, press search, client surveys

Monitor best-practice adherence to inform helpful interventions



Require badge scans when moving between rooms

Does not reflect McKinsey guidance customized to individual client needs - should be vetted against applicable legal and business requirements before application to a specific client

Source: Expert interviews, press search, client surveys

Pre-entry

Travel to work

At Work

Common areas

Post-infection

Drive safe behavior norms

Office | Field

Description of potential intervention

Install **badge scanners** at the entrance to each room and require employee use to generate live data of employee traffic for:

- Identifying **outlier employees** with high transmission potential (e.g., move through 10x more rooms and floors than avg)
- **Intervening effectively** with empirical data on movement patterns
- Better understanding **high-traffic areas** to reorganize office norms and equipment accordingly

Have **digital sign-in desks** between rooms (both monitoring and discouraging excessive movement)

Where this has been done

Corporate offices in the U.S.

Emphasize high-frequency, high-visibility cleaning (1/2)



Visible cleaning schedules displayed

High-frequency cleaning – increased to every 2 hours from every 6 hours

Clean & disinfect

Office

Description of potential intervention

Frequent cleaning of high-traffic areas / surfaces (e.g., lobbies, communal tables, cafeterias, bathrooms, elevators, stairways)

Clearly demarcate surfaces that are frequently contacted by employees to raise awareness.

Increase frequency of cleaning of demarcated surfaces throughout the workday

Increased routine sanitization of common areas to every 2 hours from every 6 hours

Where this has been done

Automotive manufacturer in S. Korea

US grocery stores

Corporate offices in the U.S.

Does not reflect McKinsey guidance customized to individual client needs - should be vetted against applicable legal and business requirements before application to a specific client

Source: Expert interviews, press search, client surveys

Emphasize high-frequency, high-visibility cleaning (2/2)

Clean & disinfect

Office

Description of potential intervention

Visible recording and monitoring of cleaning

Cleaners can update a 'confirmation of cleaning' list or display in a highly prominent location upon completion of cleaning.

Where this has been done

Corporate offices in China

US grocery stores

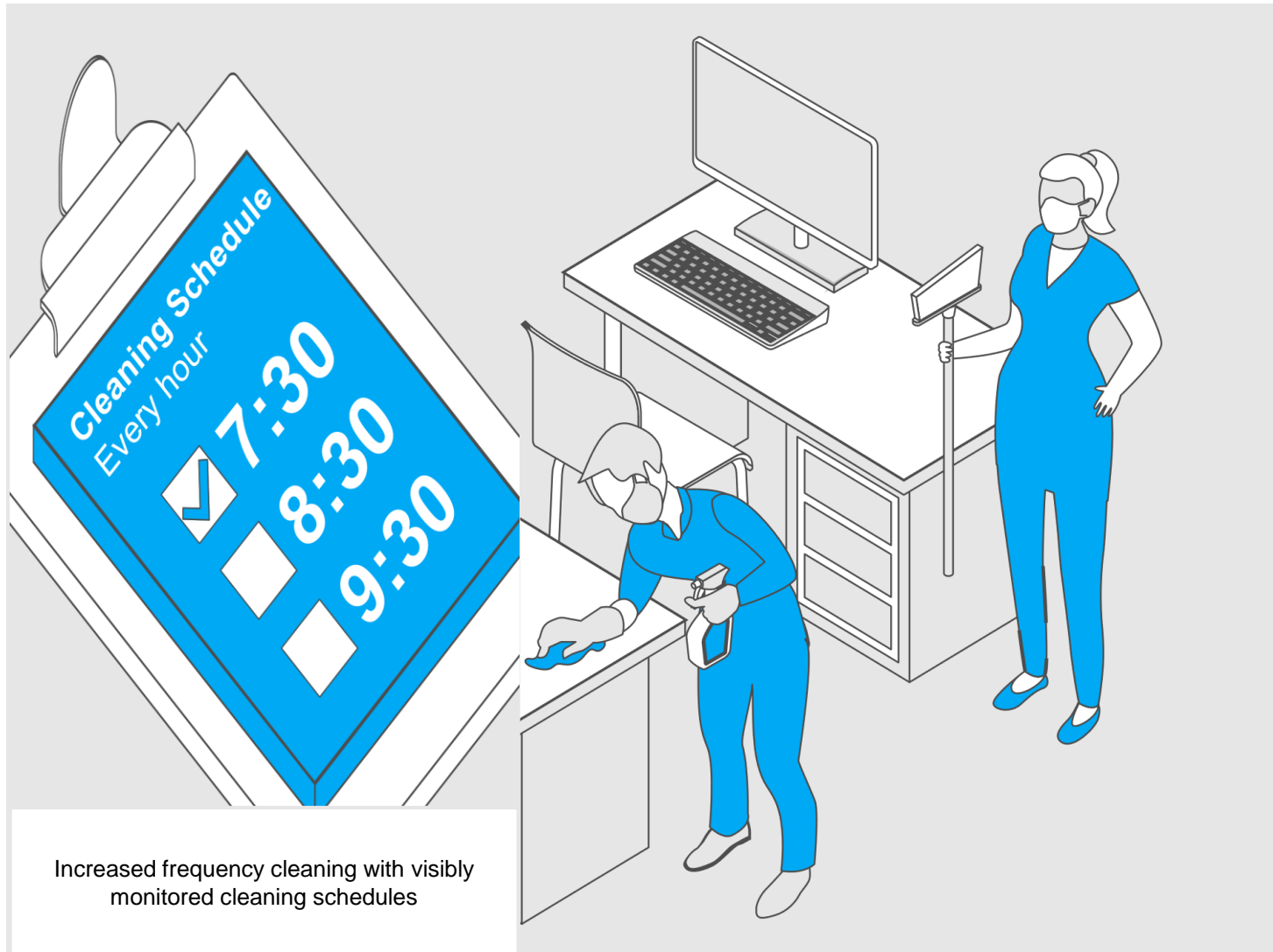

Increased frequency cleaning with visibly monitored cleaning schedules

Does not reflect McKinsey guidance customized to individual client needs - should be vetted against applicable legal and business requirements before application to a specific client

Source: Expert interviews, press search, client surveys

Ensure appropriate deep-cleaning of surfaces and spaces

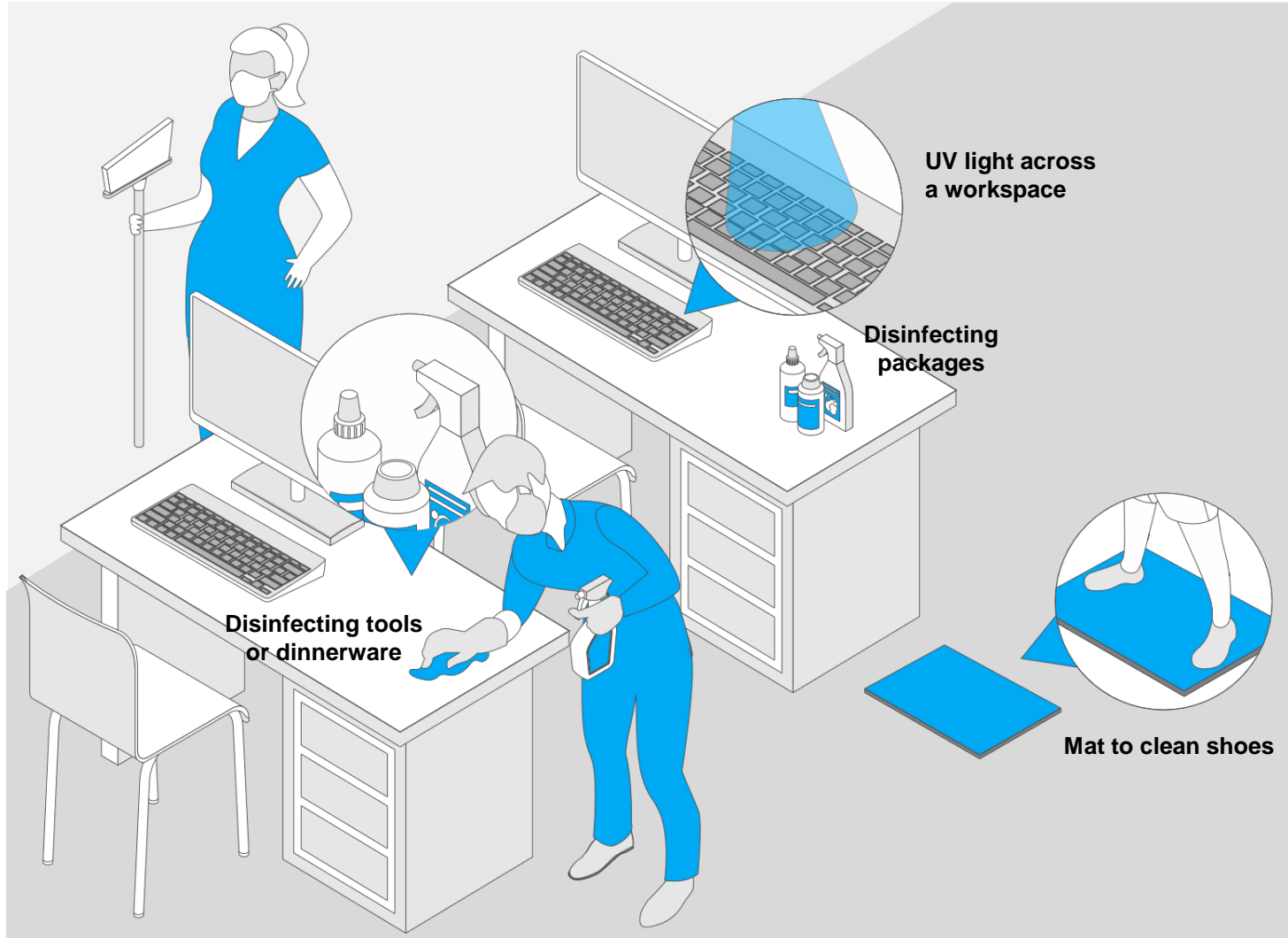

Does not reflect McKinsey guidance customized to individual client needs - should be vetted against applicable legal and business requirements before application to a specific client

Source: Expert interviews, press search, client surveys

Clean & disinfect

Office

Description of potential intervention

Use **ultraviolet germicidal irradiation** to clean critical function rooms (e.g. operations centers, real-time market trading desks, IT operations centers, call centers, kitchens, etc.)

Increase use of **iodine/ethanol for sanitization** (e.g. mat infused with product to clean shoes)

All common tools, dinnerware and kitchen equipment disinfected daily after closing with **bleach or ethanol**

All goods/packages shipped between facilities or between central kitchen and restaurants **sanitized on both ends**

Where this has been done

Large restaurant chain in China

MNC corporate offices

Improve air filtration / ventilation to remove aerial antigens

Upgrade equipment

Office

Description of potential intervention

Install high-efficiency air filters and increase ventilation rates in the work environment

Avoid using central air conditioning and heating systems where possible

Where this has been done

Multinational automotive manufacturer in S. Korea heightened ventilation requirements beyond government guidelines

Improved air filtration and ventilation systems

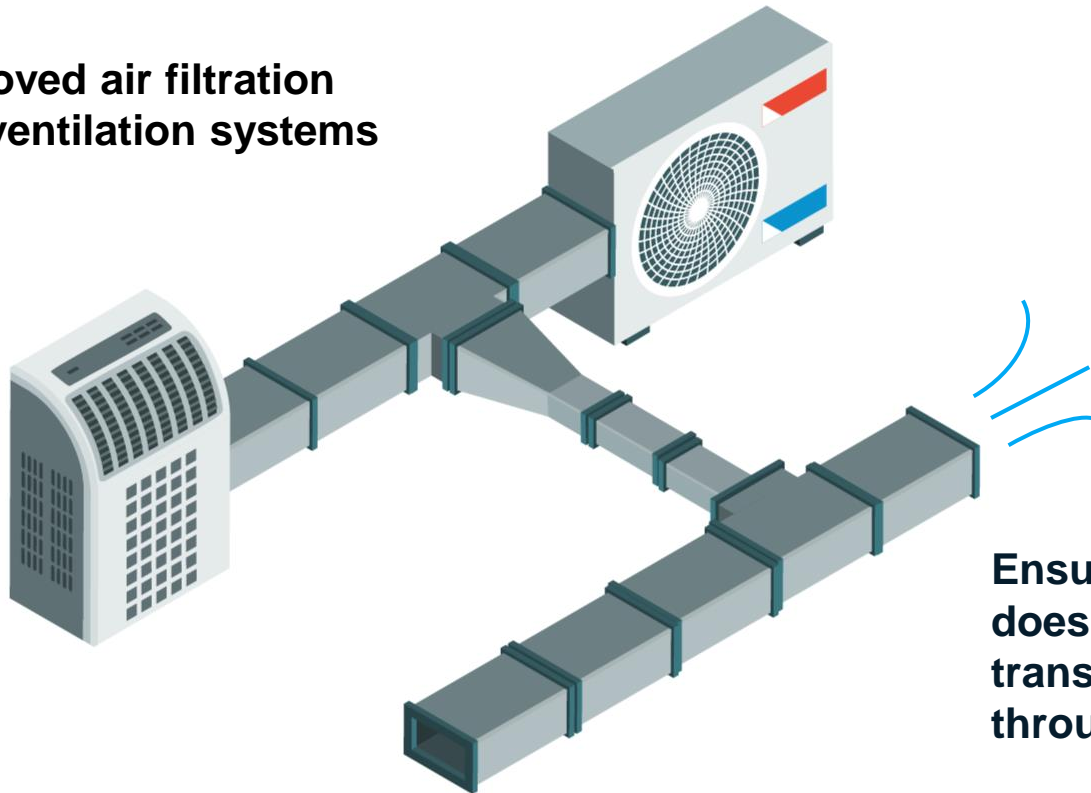

Ensure airflow does not aid transmission through droplets

HEPA (high-efficiency particulate air)-rated filter

Does not reflect McKinsey guidance customized to individual client needs - should be vetted against applicable legal and business requirements before application to a specific client

Source: Expert interviews, press search, client surveys

Install plexiglass barriers between employees and customers



Barriers between employees

Upgrade equipment

Office | Field

Description of potential intervention

Install physical glass barriers to minimize the spread of disease between employees and customers entering the store

Where this has been done

Implemented at several grocery stores and select retail stores in North America and China

Does not reflect McKinsey guidance customized to individual client needs - should be vetted against applicable legal and business requirements before application to a specific client

Source: Expert interviews, press search, client surveys

Restructure physical stores to operate as “dark stores”

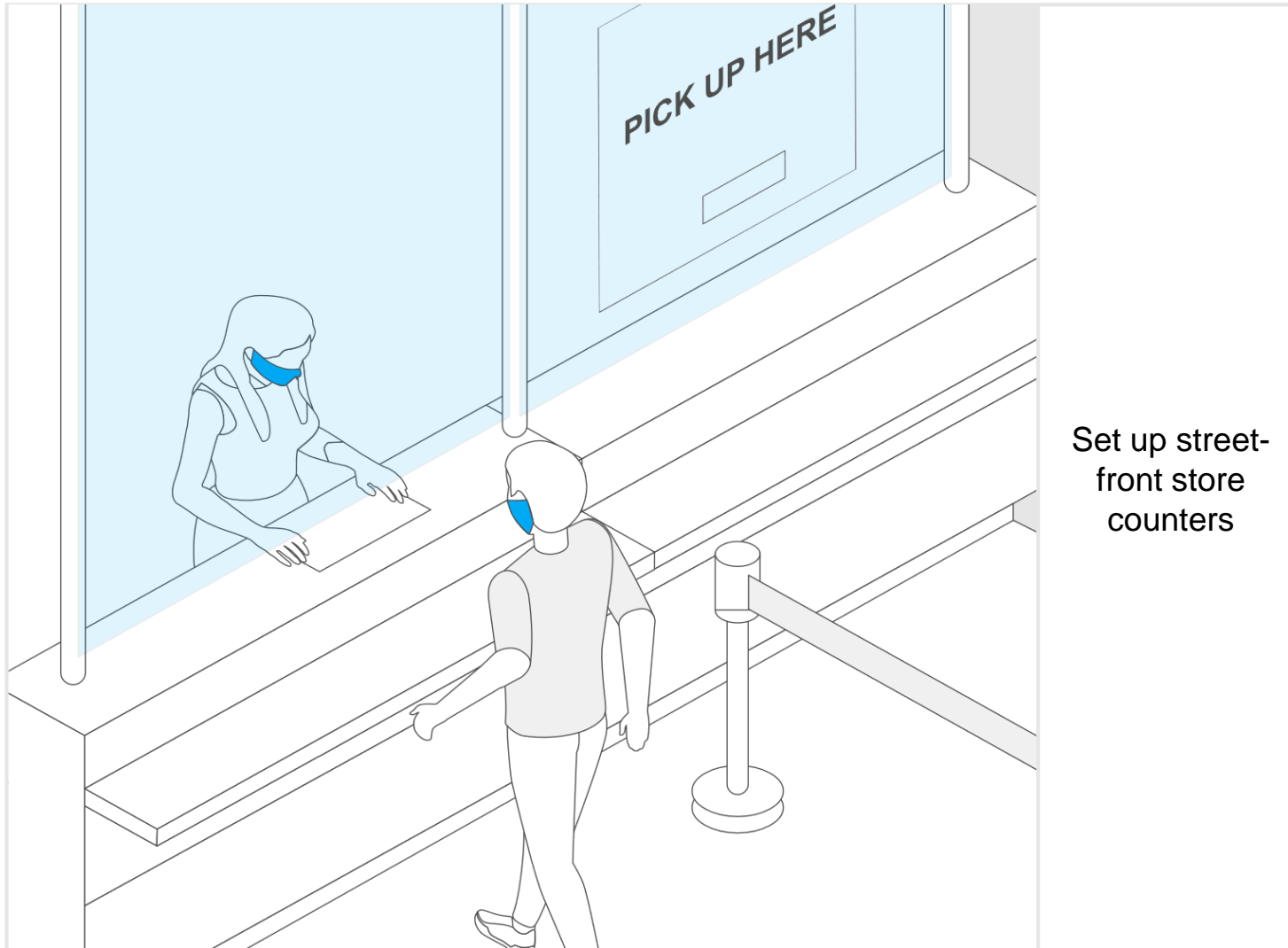

Set up street-front store counters

Does not reflect McKinsey guidance customized to individual client needs - should be vetted against applicable legal and business requirements before application to a specific client

Source: Expert interviews, press search, client surveys

Pre-entry

Travel to work

At Work

Common areas

Post-infection

Upgrade equipment

Office | Field

Description of potential intervention

Restructure physical stores to become “dark stores” (similar to dark kitchen): Locations that look like stores but are closed to customers (for online order & delivery only)

Set up street-front counters so that customers can buy vegetables, alcohol, cigarettes and other goods without entering

Where this has been done

Restaurants in China/U.S.

Small retail stores in China

Migrate entirely to contactless payment

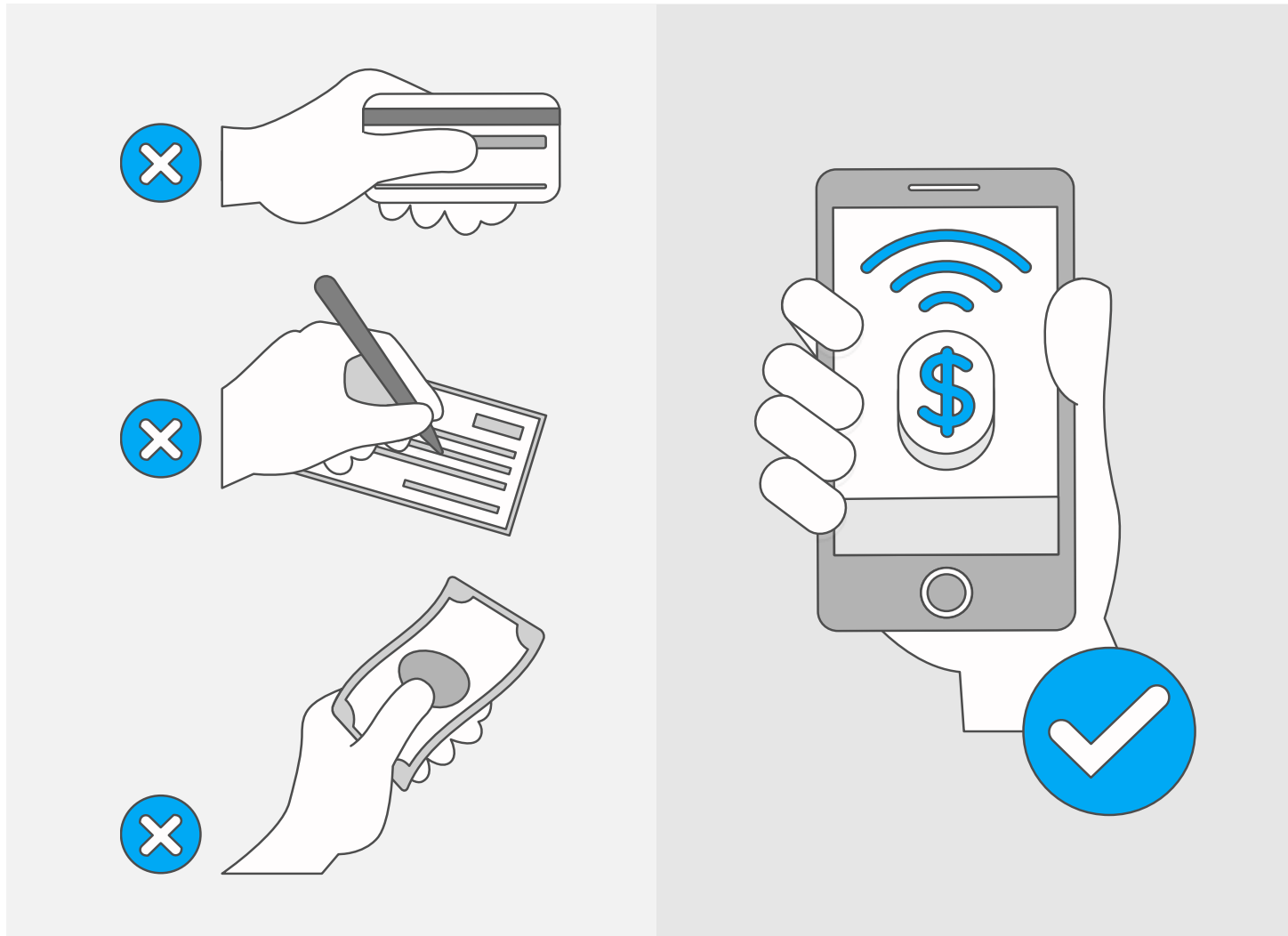

Upgrade equipment

Office | Field

Description of potential intervention

Enforce contactless transactions
(e.g., no cash, Apple Pay, WeChat Pay, contactless card taps)

Where this has been done

Large US supermarkets

Does not reflect McKinsey guidance customized to individual client needs - should be vetted against applicable legal and business requirements before application to a specific client

Source: Expert interviews, press search, client surveys

Implement curbside pick ups

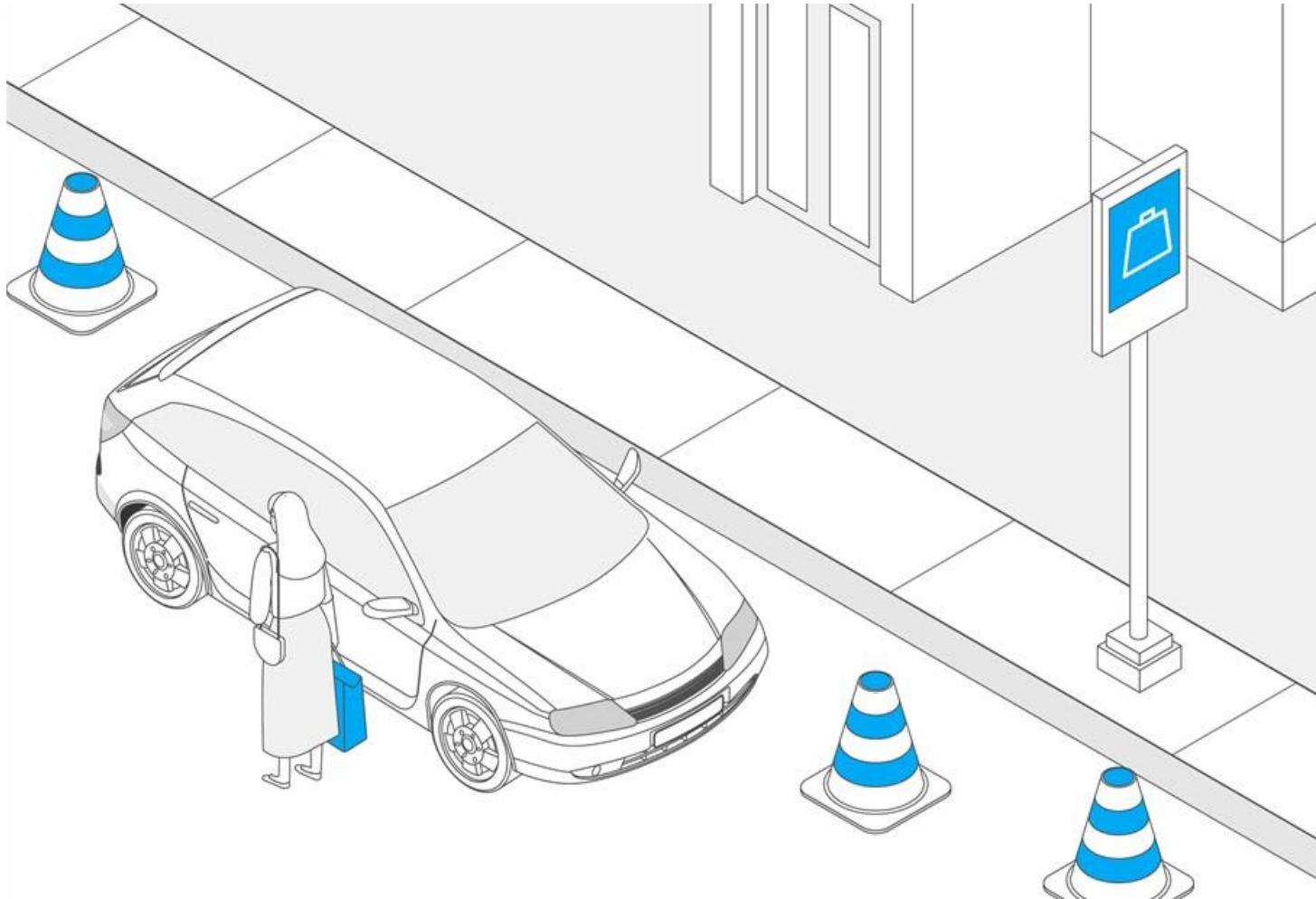

Upgrade equipment

Office | Field

Description of potential intervention

Implement curbside pickups for online or mobile app orders

Use apps to coordinate customer entry into pick up aisles

Encourage customers to use curbside pickup over in-store options

Where this has been done

Grocery and household essentials stores in the U.S.

Electronics, books and shoe stores in the U.S.

Does not reflect McKinsey guidance customized to individual client needs - should be vetted against applicable legal and business requirements before application to a specific client

Source: Expert interviews, press search, client surveys

Alter return and cancellation policies

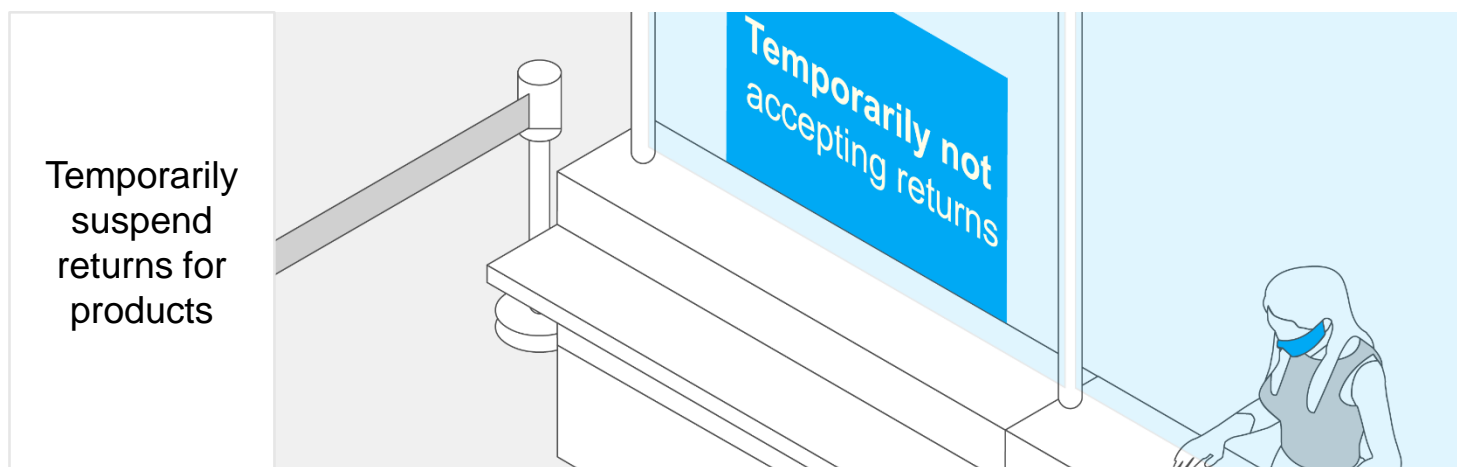

Does not reflect McKinsey guidance customized to individual client needs - should be vetted against applicable legal and business requirements before application to a specific client

Source: Expert interviews, press search, client surveys

Drive safe behavior norms

Office | Field

Description of potential intervention

Temporarily suspend return of all physical items

Extend return policy for **30 days** (or similar period) till after COVID-19 related restrictions are lifted

For pre-booked tickets, offer no-fee changes and cancellations (Airlines)

Where this has been done

Multinational retail stores in the U.S. and Canada

Global airline in Asia and Europe

Create a culture of community responsibility and collective health



Normalize individual responsibility to maintain best practices

Does not reflect McKinsey guidance customized to individual client needs - should be vetted against applicable legal and business requirements before application to a specific client

Source: Expert interviews, press search, client surveys

Drive safe behavior norms

Office | Field

Description of potential intervention

Emphasize each individual's role in the health of the entire community (e.g., one sickness can infect your colleagues, their families, the colleagues of their families)

Increase individual responsibility and accountability to self-report and stay home if they fear infection

Normalize (and even celebrate) **socially responsible behavior** (e.g., advising colleagues on safe practices, addressing hygiene violations)

Where this has been done

Pharmaceutical companies in the U.S.

Issue clear guidance on sick leave, compensation and related policies

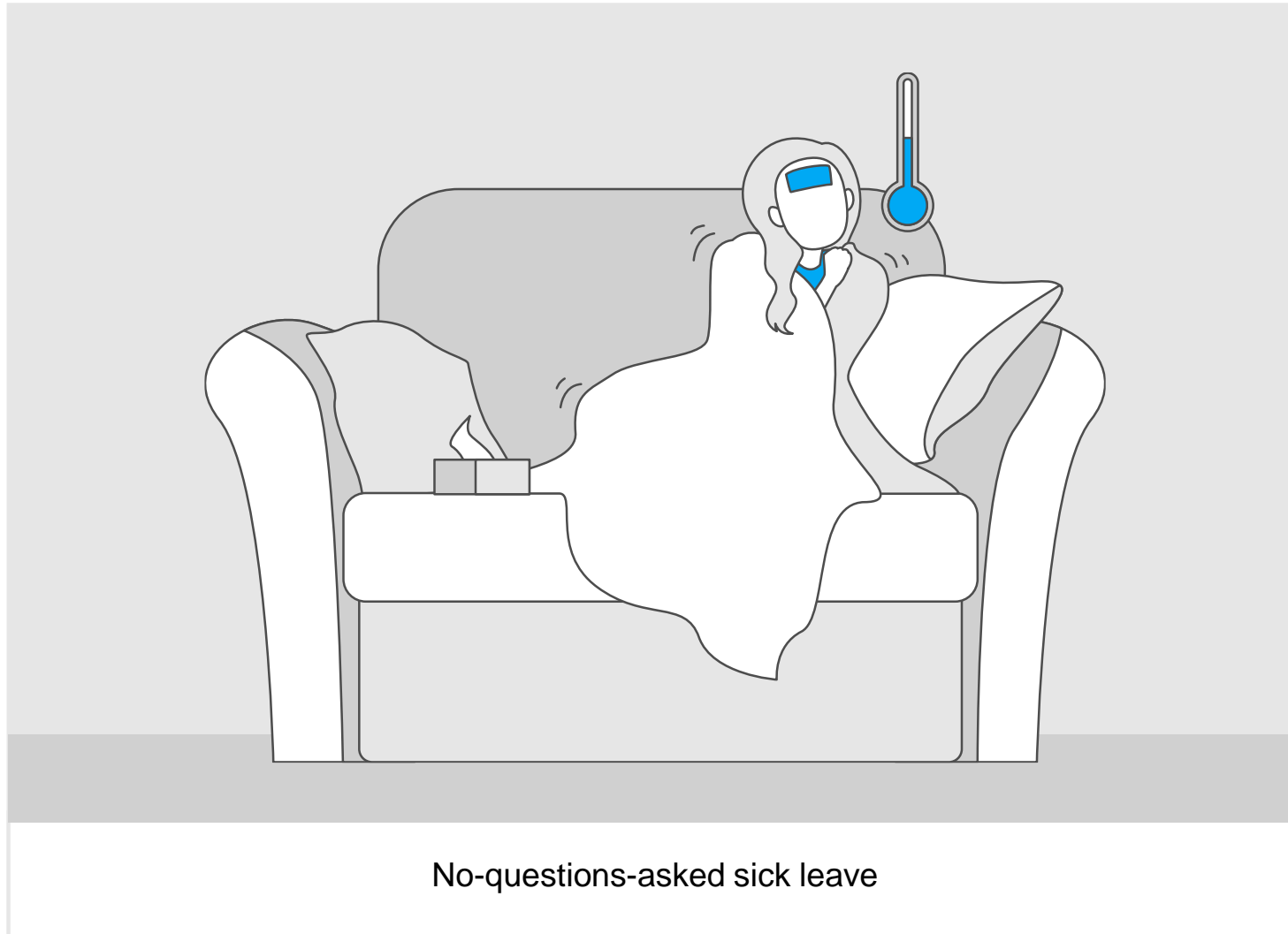

Does not reflect McKinsey guidance customized to individual client needs - should be vetted against applicable legal and business requirements before application to a specific client

Source: Expert interviews, press search, client surveys

Pre-entry

Travel to work

At Work

Common areas

Post-infection

Drive safe behavior norms

Office | Field

Description of potential intervention

Institute a flexible sick leave policy (e.g., no-questions-asked) to help drive an office culture of responsibly staying home with any symptoms.

Proactively develop and communicate compensation, attendance and reliability, PTO, and related policies that will apply during the ongoing conditions

Reimburse sick time off and institute short-term disability leave programs and emergency leave policy

Where this has been done

US grocery stores

Implement strict domestic, national and international travel policies

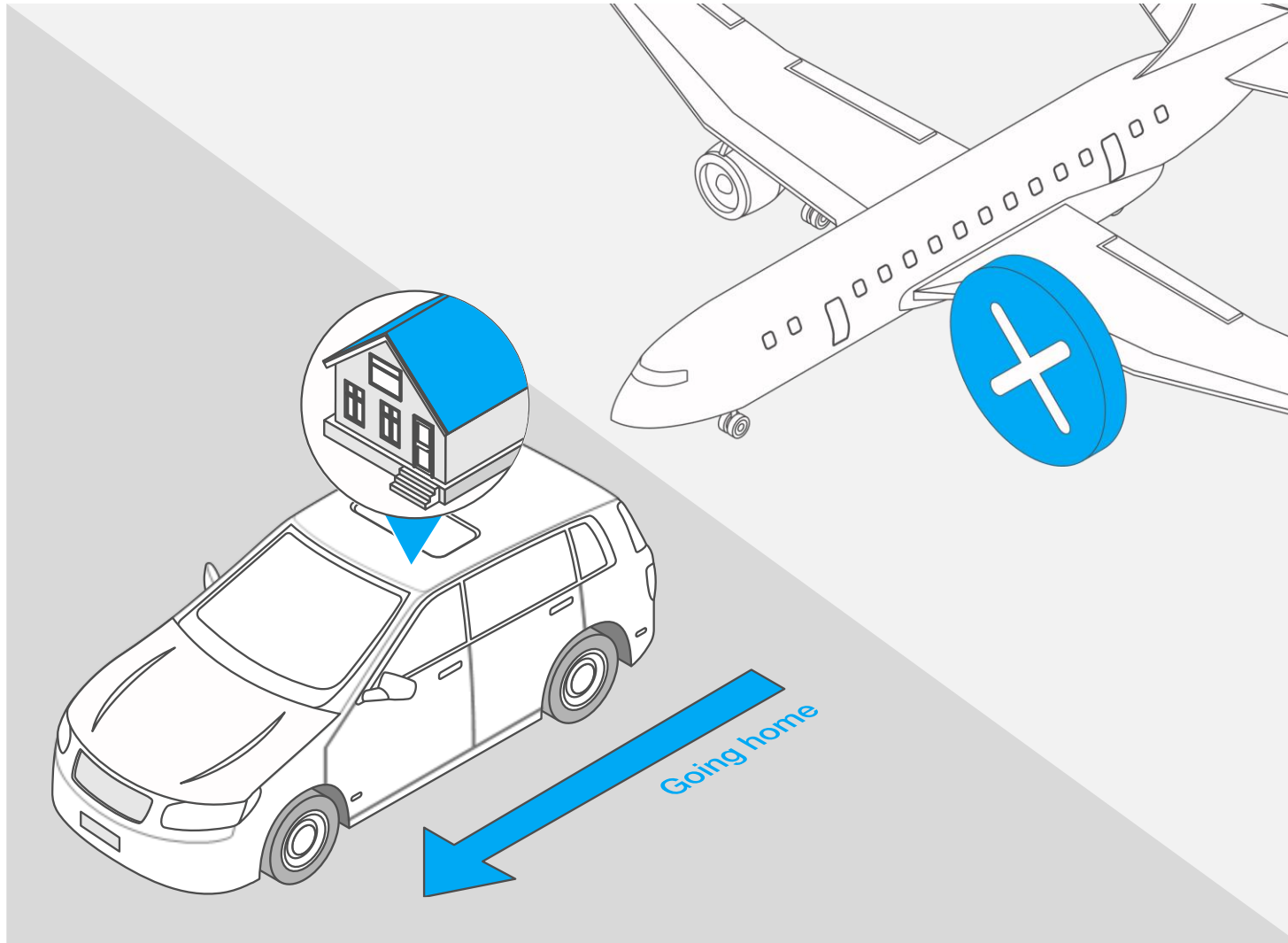

Does not reflect McKinsey guidance customized to individual client needs - should be vetted against applicable legal and business requirements before application to a specific client

Source: Expert interviews, press search, client surveys

Pre-entry

Travel to work

At Work

Common areas

Post-infection

Drive safe behavior norms

Office | Field

Description of potential intervention

Require employees to **report all national and international travel** and issue guidance on self-quarantines

Prohibit non-essential travel (domestic, international, or even within the city)

Advise employees who exit the building for external business meetings during the day to **go straight to home rather than return to office**

Where this has been done

Multinational corporations in the U.S., U.K.

Conglomerates in South Korea

Common space

Identify high risk areas based on a walkthrough assessment

Drive safe behavior norms

Office | Field

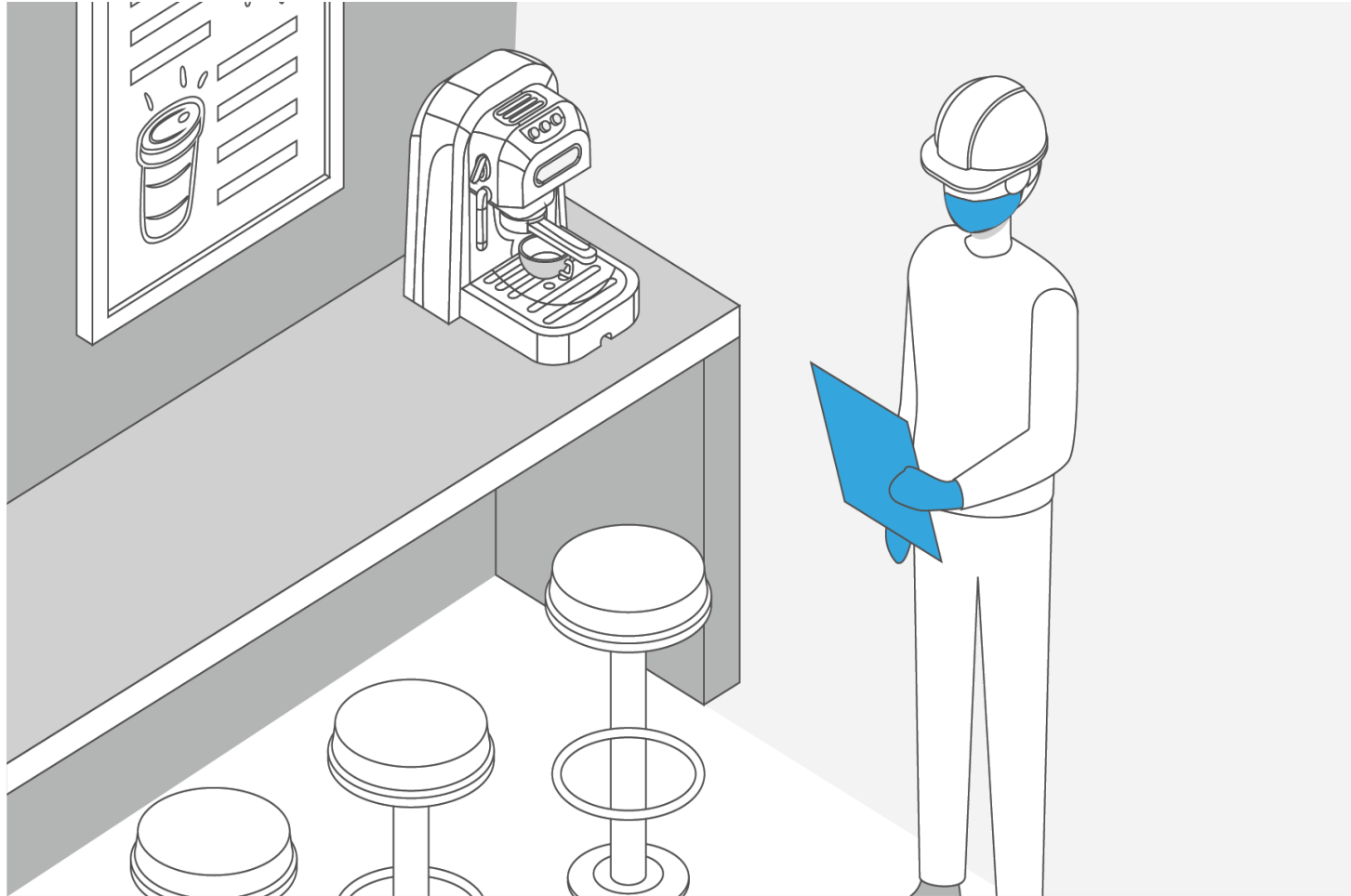

Third party walk-through

Description of potential intervention

Have an employee, employee team or third-party perform a walkthrough assessment to identify high-risk, high-touch areas

Use this assessment to inform new safety measures

Where this has been done

Multinational aerospace manufacturer

Does not reflect McKinsey guidance customized to individual client needs - should be vetted against applicable legal and business requirements before application to a specific client

Source: Expert interviews, press search, client surveys

Remove or replace high-touch communal resources

Pre-entry

Travel to work

At Work

Common areas

Post-infection

Upgrade equipment

Office | Field

Description of potential intervention

Remove or provide alternatives for high-touch communal resources with individualized services. For example:

- Replace coffee machines with individual coffee deliveries
- Use bottles water or motion sensing water dispensers in place of water fountains
- Remove vending machines

Where this has been done

Multinational aerospace manufacturer

Corporate offices in the US

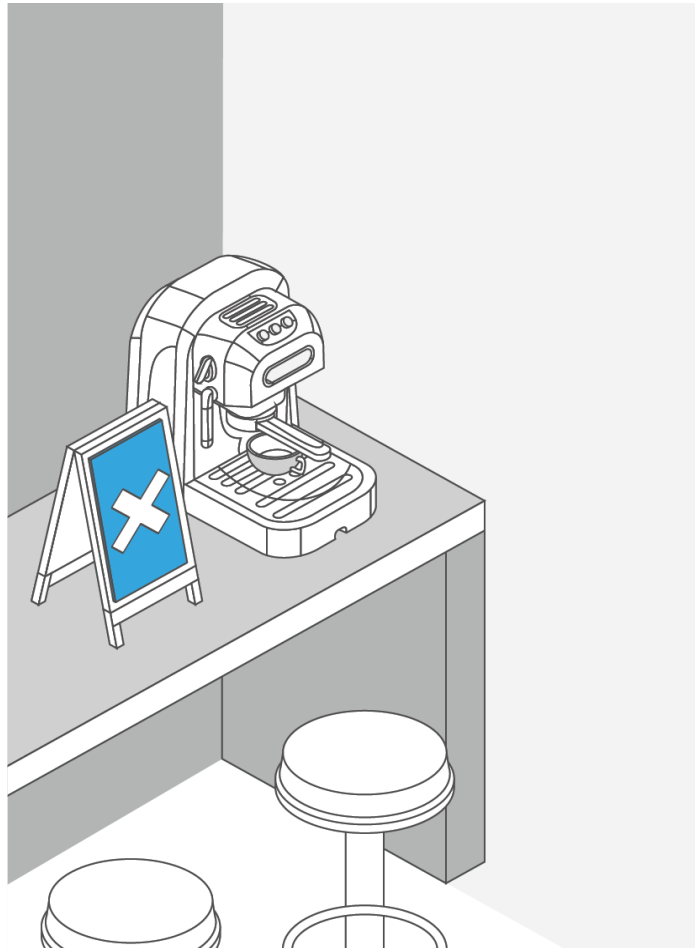

Replacing coffee dispensers

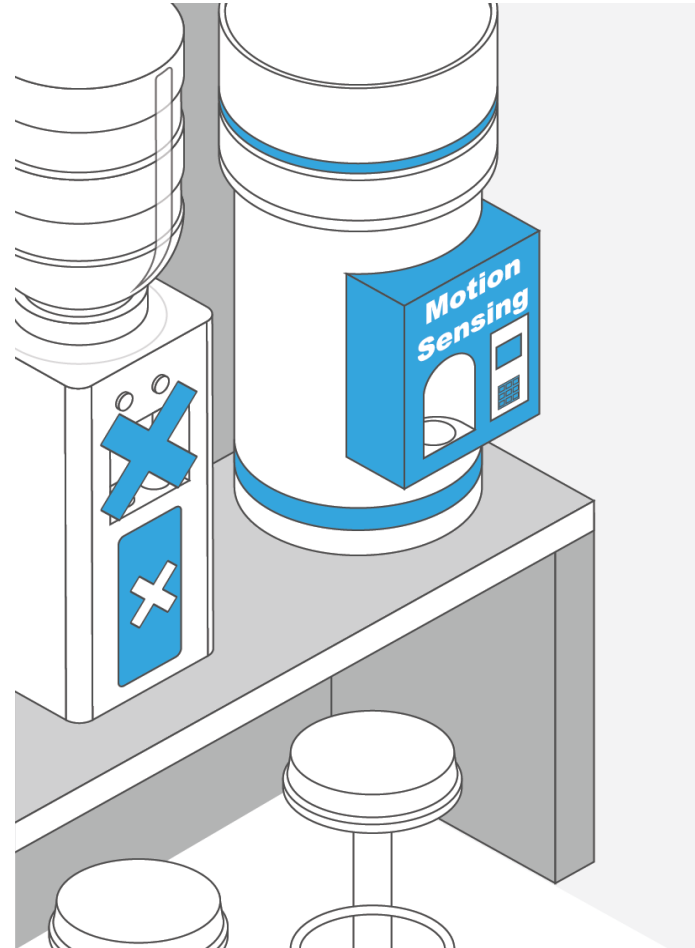

Installing motion sensing water filling stations

Does not reflect McKinsey guidance customized to individual client needs - should be vetted against applicable legal and business requirements before application to a specific client

Source: Expert interviews, press search, client surveys

Close common areas and provide strict protocols for when they reopen

Pre-entry

Travel to work

At Work

Common areas

Post-infection

Separate in space & time

Office | Field

Description of potential intervention

Common areas to be cordoned off initially

Specify employee usage protocols for all must-use common areas including pre-booking spaces for use, cleaning before and after use, limiting the capacity, etc

Where this has been done

Corporate offices in China

Conglomerates in S. Korea

Multinational automotive manufacturer in S. Korea

Multinational aerospace manufacturer

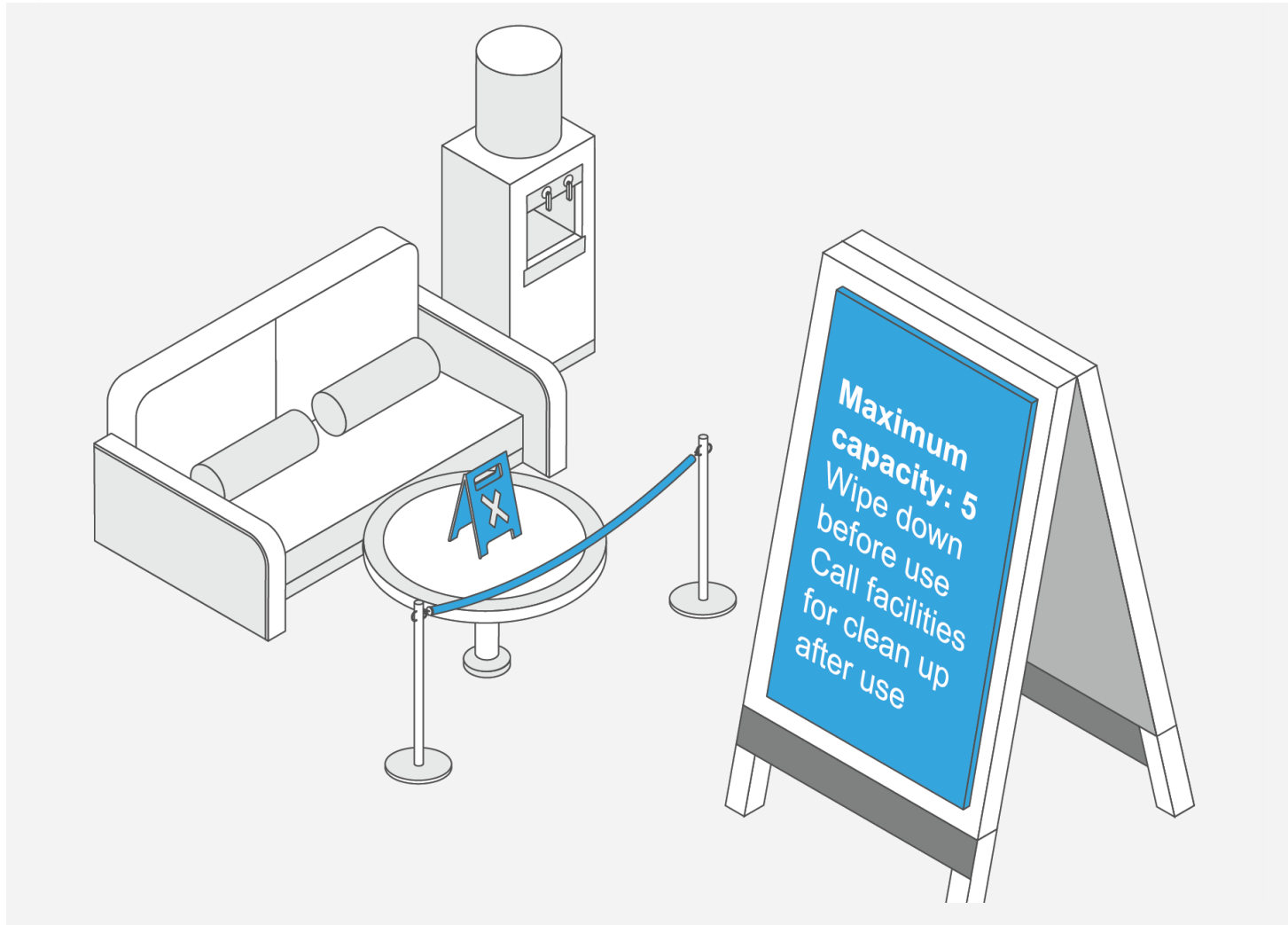

Does not reflect McKinsey guidance customized to individual client needs - should be vetted against applicable legal and business requirements before application to a specific client

Source: Expert interviews, press search, client surveys

Minimize use of handles and physical interfaces

Upgrade equipment

Office | Field



Modified surface to minimize contact

Description of potential intervention

Greater use of motion-control doors and interfaces throughout the workspace.

- Reduces the risk of workers contacting a contaminated surface.
- Could help to reduce the cleaning requirement

If motion control is not available, option to **modify item to minimize contact** such as foot operated door handles

Remove need for physical interface where possible such as leaving doors open

Where this has been done

Corporate offices in China

Global corporate offices of fast food chain is installing hand free door openers and towel dispensers

Does not reflect McKinsey guidance customized to individual client needs - should be vetted against applicable legal and business requirements before application to a specific client

Source: Expert interviews, press search, client surveys

Limit larger gatherings/ meetings of employees

Encourage
video/audio
calls



Repurpose
conference
rooms



Does not reflect McKinsey guidance customized to individual client needs - should be vetted against applicable legal and business requirements before application to a specific client

Source: Expert interviews, press search, client surveys

Pre-entry

Travel to work

At Work

Common areas

Post-infection

Drive safe behavior norms

Office | Field

Description of potential intervention

Limit in-person gatherings to no more than 2 people to a room

Cancel non-business-critical, in-person activities (e.g., happy hours, community service)

Hold necessary group meetings (e.g., Town Hall, Steering Committee, Board meetings) **via Video Conference** wherever possible (even if employees are in the office)

Where this has been done

American multinational companies

Corporate offices in South Korea

Limit capacity in elevators

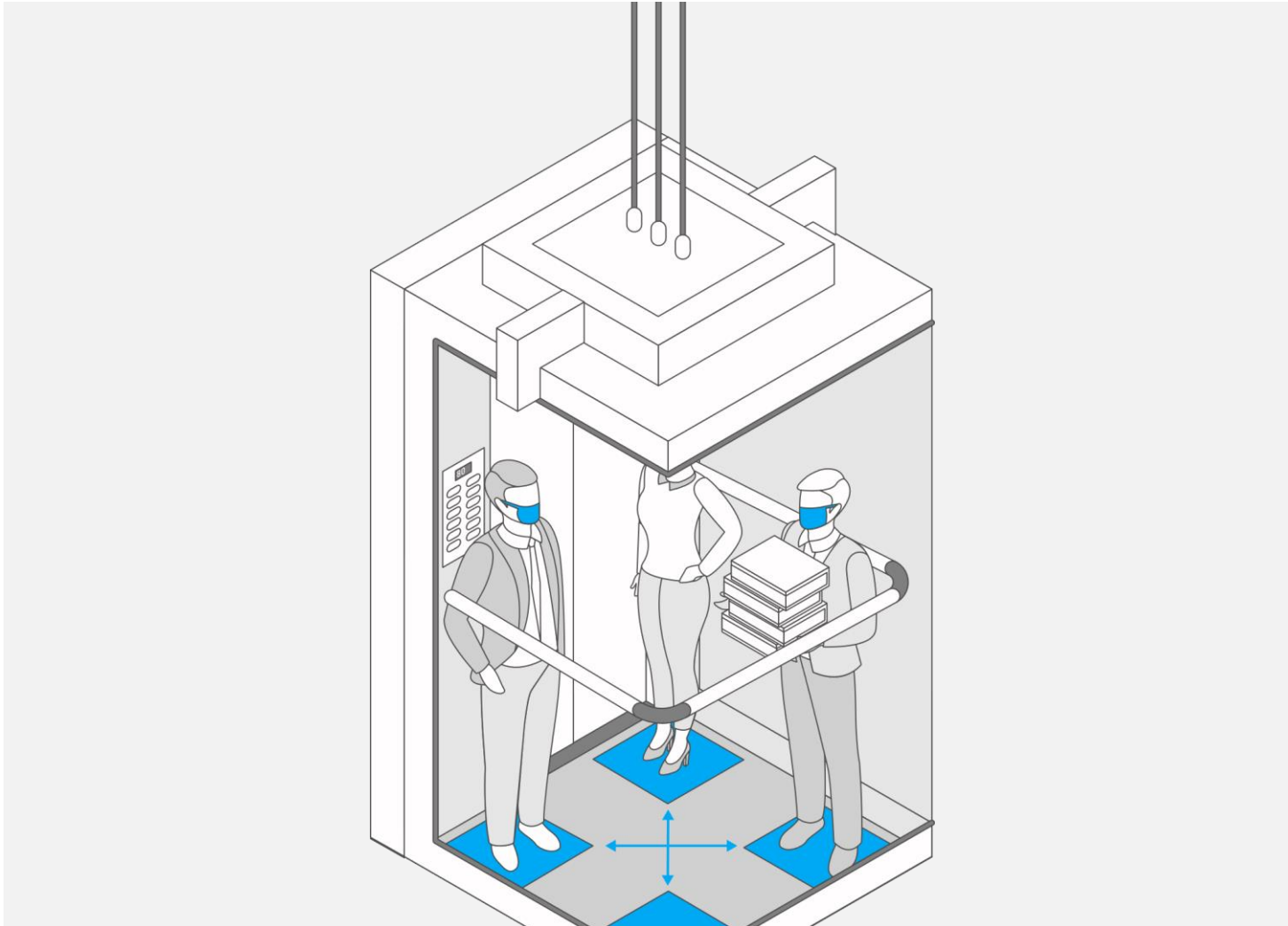

Separate in space & time

Office | Field

Description of potential intervention

Limit capacity of elevators to enforce physical distancing (e.g., 2 people in small elevators, 4 in large)

Where this has been done

International quick-service restaurant chain in China

Residential complexes in the U.S.

Corporate offices in China

Does not reflect McKinsey guidance customized to individual client needs - should be vetted against applicable legal and business requirements before application to a specific client

Source: Expert interviews, press search, client surveys

Improve air filtration / ventilation to remove aerial antigens

Improved air filtration and ventilation systems

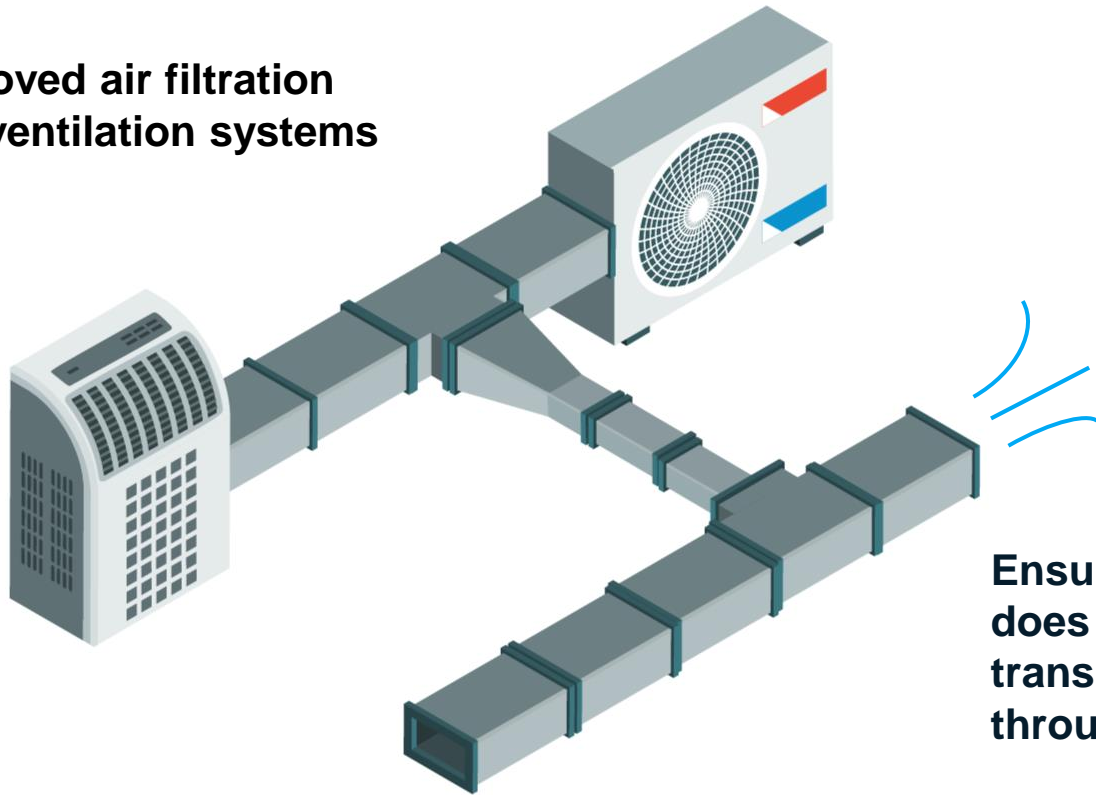

Ensure airflow does not aid transmission through droplets

HEPA (high-efficiency particulate air)-rated filter

Does not reflect McKinsey guidance customized to individual client needs - should be vetted against applicable legal and business requirements before application to a specific client

Source: Expert interviews, press search, client surveys

Upgrade equipment

Office | Field

Description of potential intervention

Install high-efficiency air filters and increase ventilation rates in the work environment

Avoid using central air conditioning and heating systems where possible

Where this has been done

Multinational automotive manufacturer in S. Korea heightened ventilation requirements beyond government guidelines

Monitor best-practice adherence to inform helpful interventions



Require badge scans when moving between rooms

Does not reflect McKinsey guidance customized to individual client needs - should be vetted against applicable legal and business requirements before application to a specific client

Source: Expert interviews, press search, client surveys

Drive safe behavior norms

Office | Field

Description of potential intervention

Install **badge scanners** at the entrance to each room and require employee use to generate live data of employee traffic for:

- Identifying **outlier employees** with high transmission potential (e.g., move through 10x more rooms and floors than avg)
- **Intervening effectively** with empirical data on movement patterns
- Better understanding **high-traffic areas** to reorganize office norms and equipment accordingly

Have **digital sign-in desks** between rooms (both monitoring and discouraging excessive movement)

Where this has been done

Corporate offices in the U.S.

Emphasize high-frequency, high-visibility cleaning (1/2)



Visible cleaning schedules displayed

High-frequency cleaning – increased to every 2 hours from every 6 hours

Clean & disinfect

Office | Field

Description of potential intervention

Frequent cleaning of high-traffic areas / surfaces (e.g., lobbies, communal tables, cafeterias, bathrooms, elevators, stairways)

Clearly demarcate surfaces that are frequently contacted by employees to raise awareness.

Increase frequency of cleaning of demarcated surfaces throughout the workday

Increased routine sanitization of common areas to every 2 hours from every 6 hours

Where this has been done

Automotive manufacturer in S. Korea

US grocery stores

Corporate offices in the U.S.

Does not reflect McKinsey guidance customized to individual client needs - should be vetted against applicable legal and business requirements before application to a specific client

Source: Expert interviews, press search, client surveys

Emphasize high-frequency, high-visibility cleaning (2/2)

Clean & disinfect

Office | Field

Description of potential intervention

Visible recording and monitoring of cleaning

Cleaners can update a 'confirmation of cleaning' list or display in a highly prominent location upon completion of cleaning.

Where this has been done

Corporate offices in China

US grocery stores

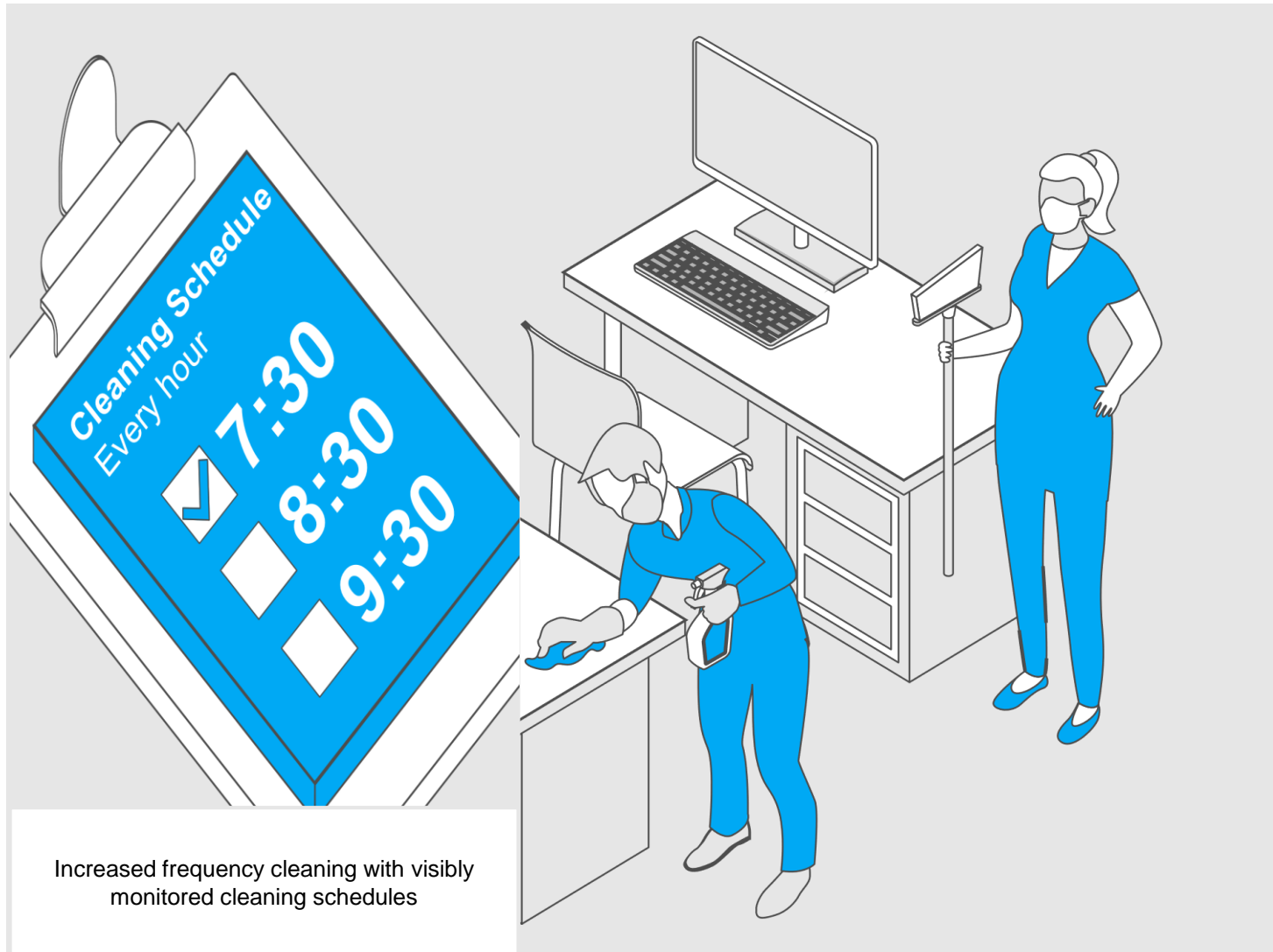

Increased frequency cleaning with visibly monitored cleaning schedules

Does not reflect McKinsey guidance customized to individual client needs - should be vetted against applicable legal and business requirements before application to a specific client

Source: Expert interviews, press search, client surveys

Ensure appropriate deep-cleaning of surfaces and spaces

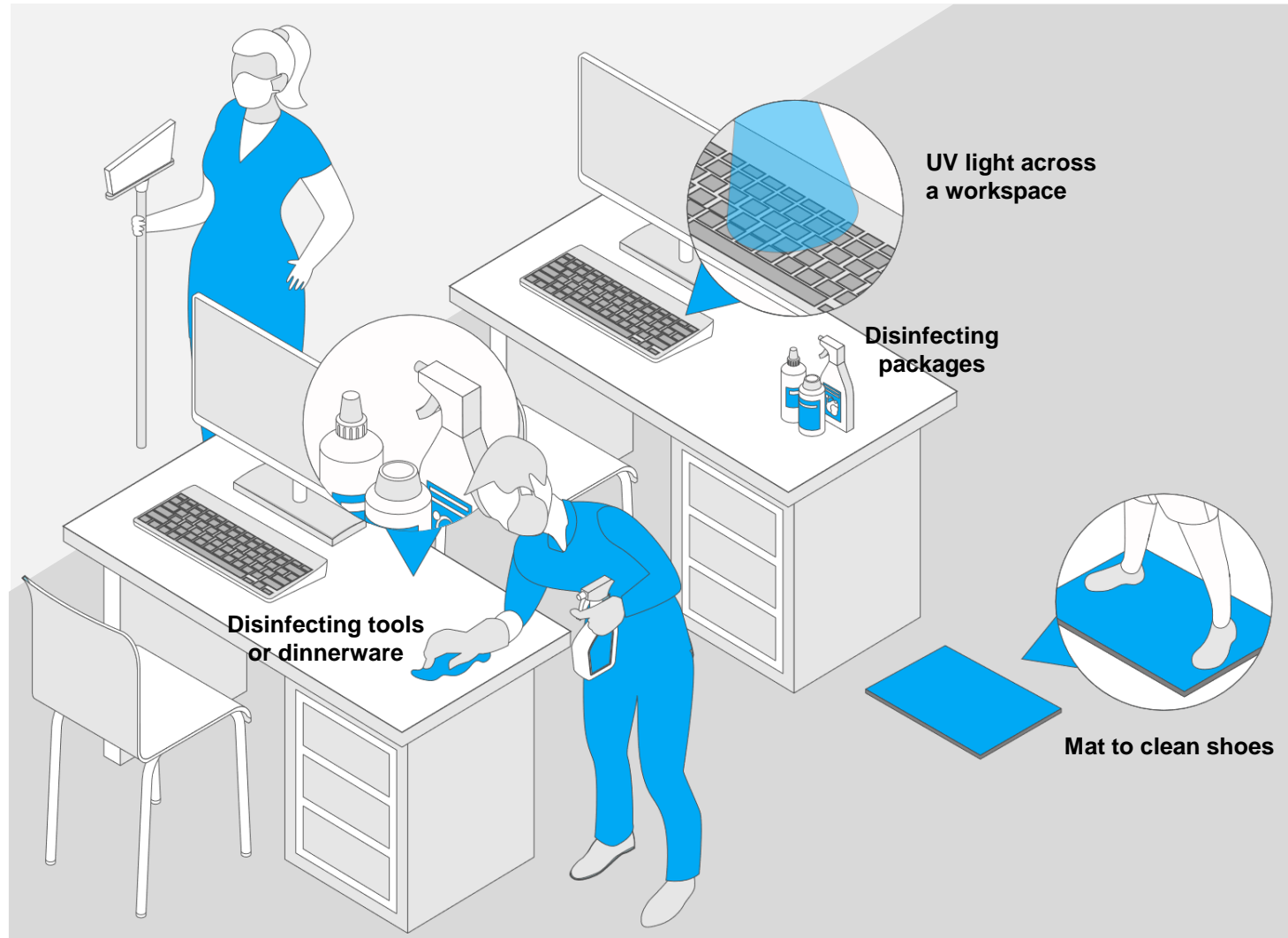

Does not reflect McKinsey guidance customized to individual client needs - should be vetted against applicable legal and business requirements before application to a specific client

Source: Expert interviews, press search, client surveys

Clean & disinfect

Office | Field

Description of potential intervention

Use **ultraviolet germicidal irradiation** to clean critical function rooms (e.g. operations centers, real-time market trading desks, IT operations centers, call centers, kitchens, etc.)

Increase use of **iodine/ethanol for sanitization** (e.g. mat infused with product to clean shoes)

All common tools, dinnerware and kitchen equipment disinfected daily after closing with **bleach or ethanol**

All goods/packages shipped between facilities or between central kitchen and restaurants **sanitized on both ends**

Where this has been done

Large restaurant chain in China

MNC corporate offices

Encourage or mandate appropriate PPE¹ gear (1/2)

Use protective equipment

Office | Field

PPE required or provided at entry

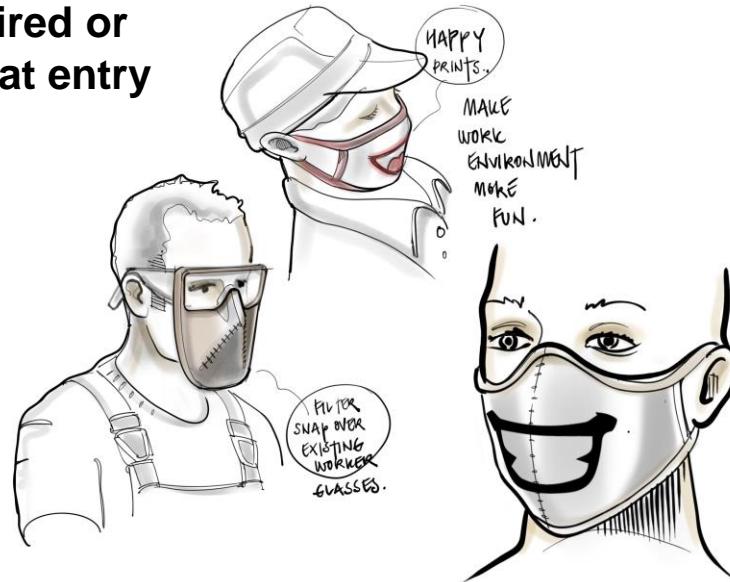

Safe working kits



1 Critical PPE (surgical masks, N-95, etc.) must continue to be reserved for healthcare workers and other medical first responders. Use should be in accordance with local government and health organization guidelines

Description of potential intervention

Forbid anyone who doesn't wear face masks from entering into company buildings

Alternatively, recommend face masks and gloves in all or specifically-designated areas of the company

Compensate employees for buying facemasks

Provide face masks (and safe working kits) to employees for free and distribute upon entry

Where this has been done

South Korean conglomerates

S. Korean multinational automotive manufacturer began preparation of mask production for its own employees













China: Multinational clothing retail brands

Does not reflect McKinsey guidance customized to individual client needs - should be vetted against applicable legal and business requirements before application to a specific client

Source: Expert interviews, press search, client surveys

Encourage or mandate appropriate PPE¹ gear (2/2)

Details in Appendix

PPE Usage				
OSHA Risk Level	Respirators and masks	Gowns	Eye protection	Gloves
 High-Very High Risk				
 Medium Risk				
 Low Risk		<div style="border: 1px solid black; padding: 5px;"> Infrequent use of respirators and gowns in medium risk category¹ </div>		
<p>1 Critical PPE (surgical masks, N-95, etc.) must continue to be reserved for healthcare workers and other medical first responders. Use should be in accordance with local government and health organization guidelines</p>				

Does not reflect McKinsey guidance customized to individual client needs - should be vetted against applicable legal and business requirements before application to a specific client

Source: Expert interviews, press search, client surveys

Use protective equipment

Office | Field

Description of potential intervention

Encourage or mandate PPE usage based on work environment:

- Healthcare workers given preference for N95 respirators (use for 5-7 days) or provided 2 masks a day
- Production employees wear polyester gloves and glasses
- Office employees and customer-facing employees given daily masks (cloth masks suffice)

Where this has been done

- Aerospace and Defense manufacturer in China
- Companies in South Korea
- Clothing retail stores in China
- Grocery stores in the U.S.

Promote healthy personal habits with high-visibility signage and media campaigns

Increase awareness

Office | Field

Description of potential intervention

Promote healthy habits with **high-visibility signage** across the workspace (e.g., wash hands frequently)

Leverage media and advertising to create awareness among employees and customers

Where this has been done

Corporate offices in China

Corporate offices in US (prior to full closure)

Several multinational retail brands have used advertising to promote social distancing

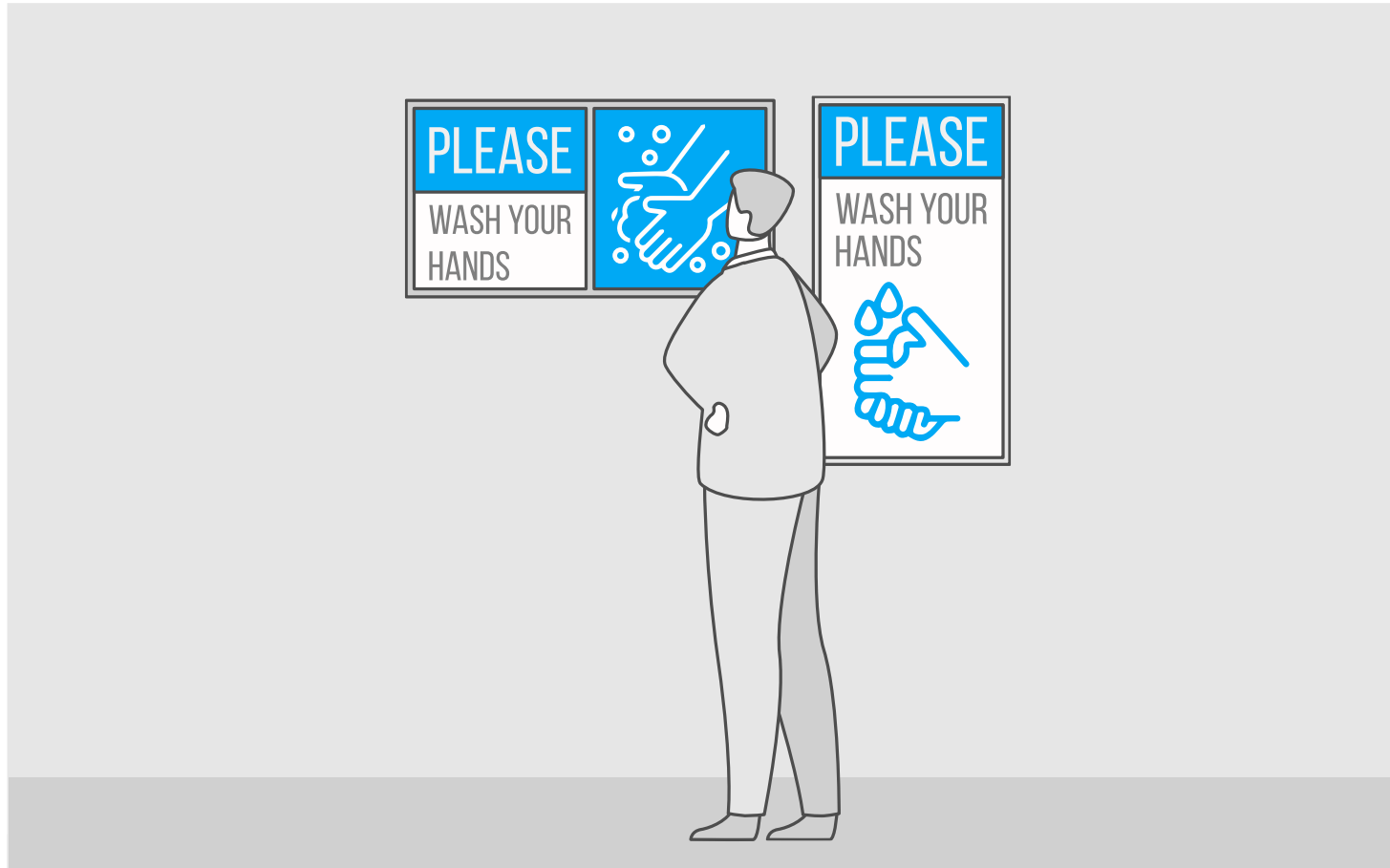

Clearly denote expected practices

Does not reflect McKinsey guidance customized to individual client needs - should be vetted against applicable legal and business requirements before application to a specific client

Source: Expert interviews, press search, client surveys

Highlight new workplace safety processes and policies through prominent displays

Increase awareness

Office | Field

Informational materials in displays and advertising



Description of potential intervention

Display large format posters or digital displays providing prominent, frequent reminders to employees of the new workplace situation, protocols and (crucially) the rationale behind it

Where this has been done

Corporate offices in China

Does not reflect McKinsey guidance customized to individual client needs - should be vetted against applicable legal and business requirements before application to a specific client

Source: Expert interviews, press search, client surveys

Stagger lunch hours and time spent in common areas

Separate in space & time

Office | Field

Staggered lunch schedule

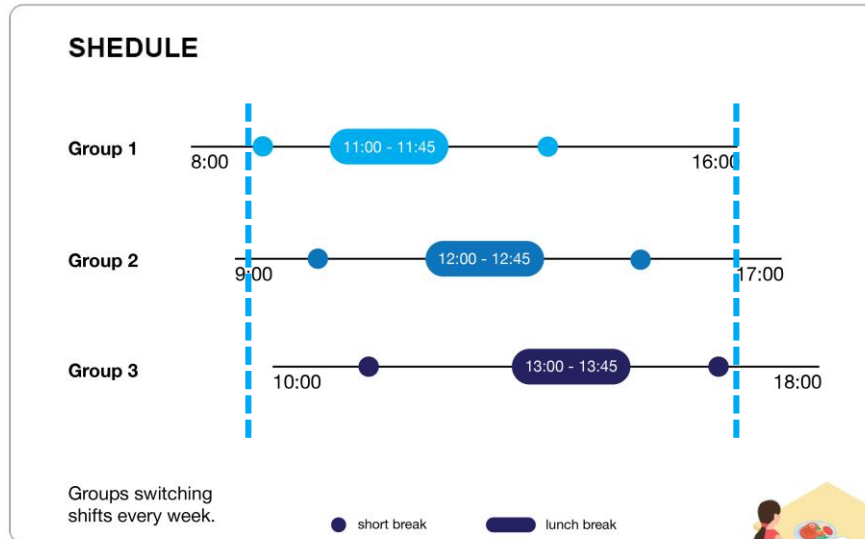

Extended cafeteria operating hours

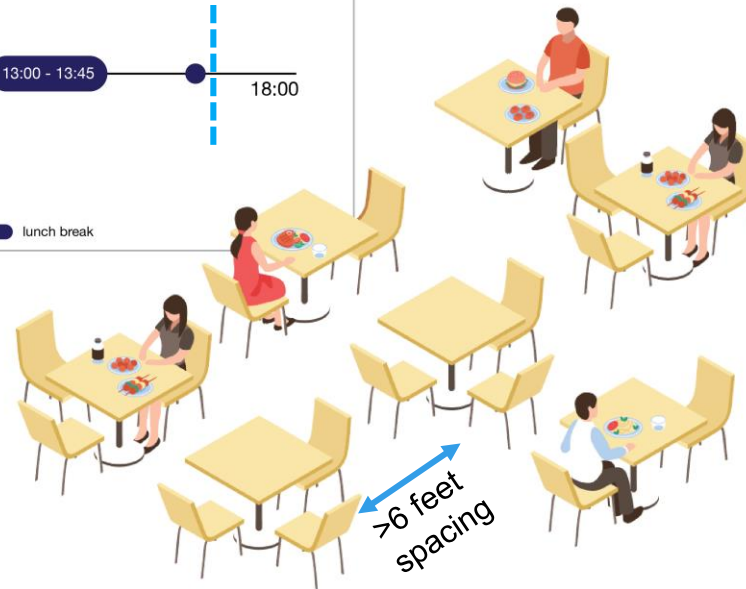

Description of potential intervention

Stagger lunch hours in order to distribute the amount of people coming to cafeteria at a time

Extend operating hours for cafeterias in order to reduce density of people present in the space at any time

Similarly, stagger other routine activities in common areas

Where this has been done

- Corporate offices in China
- Offices and manufacturing plants in S. Korea

Does not reflect McKinsey guidance customized to individual client needs - should be vetted against applicable legal and business requirements before application to a specific client

Source: Expert interviews, press search, client surveys

Encourage physical distancing in cafeterias

Pre-entry

Travel to work

At Work

Common areas

Post-infection

Separate in space & time

Office | Field

Description of potential intervention

Prevent physical proximity in cafeteria

- **Set up partitions on dining tables**
- **Prohibit employees from sitting next to and facing each other at cafeterias (checker board arrangement)**
- **Recommend to minimize chatting while eating**

Where this has been done

Corporate offices in China

Offices and manufacturing plants in S. Korea

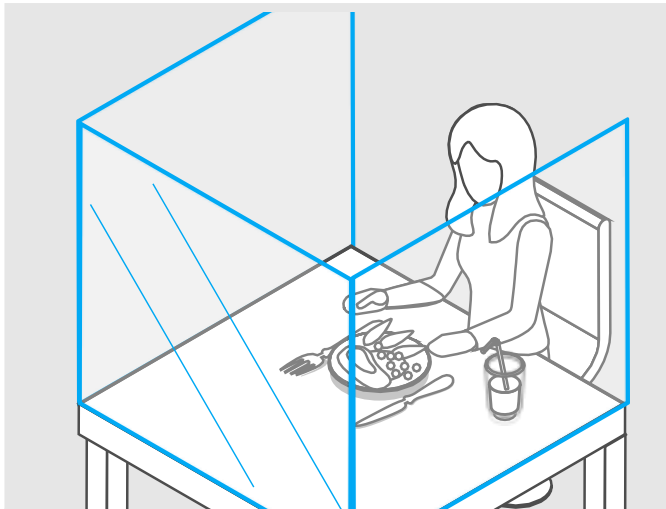

Separated lunch seating with dividers on dining tables

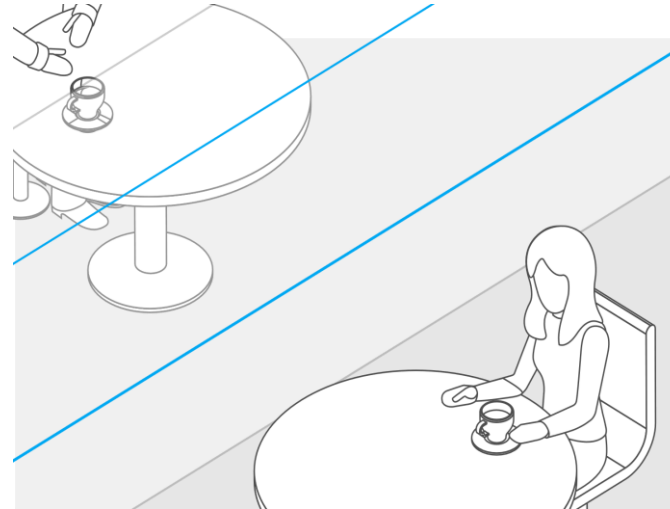

Tables spaces over 6 ft apart

Does not reflect McKinsey guidance customized to individual client needs - should be vetted against applicable legal and business requirements before application to a specific client

Source: Expert interviews, press search, client surveys

Reduce or replace communal and self-serve options in food service

Upgrade equipment

Office | Field

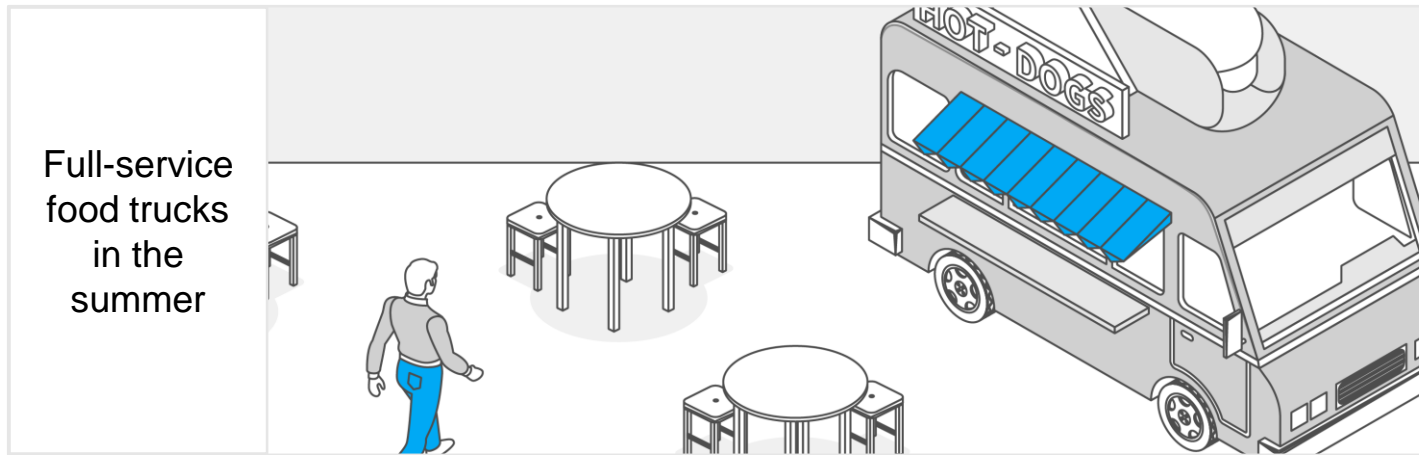
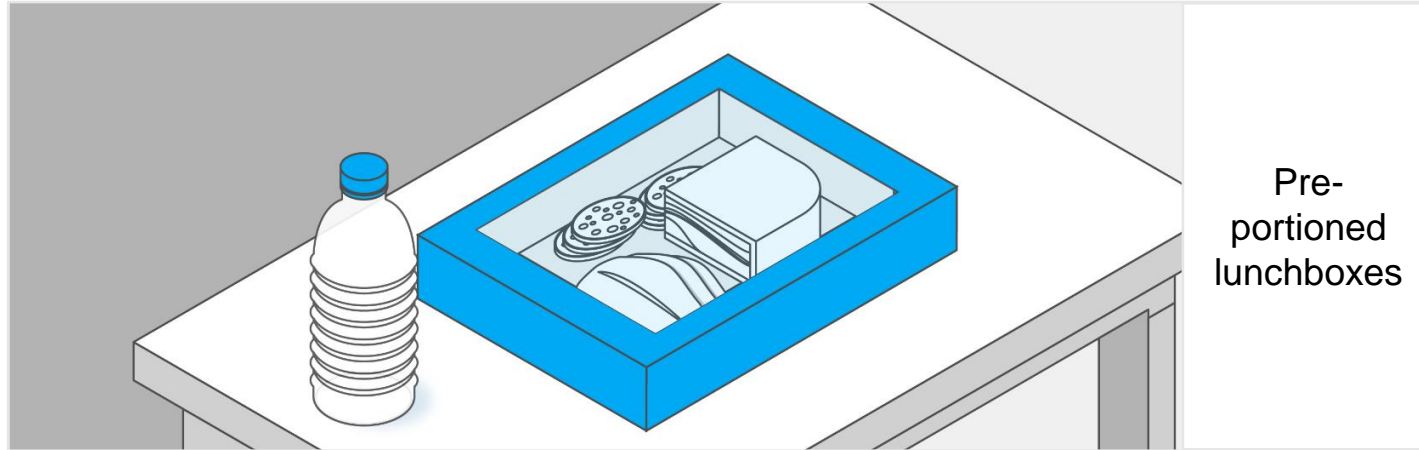

Description of potential intervention

Swap self-service lunch options like buffets for pre-packaged and portioned meals – minimizing shared utensils and exposure risk to the meal.

In the summer, this can be done through **food trucks in an open space**

Remove condiments or items at tables that persist between customers

Remove self-service food extras such as drink dispensers, napkins, utensil trays, etc

Where this has been done

Corporate offices in China

Multinational automotive manufacturer in S. Korea increased lunch box delivery volume in cafeterias

Health protection agency in Scotland has warned hospitality industries against communal meal sharing and buffets

Does not reflect McKinsey guidance customized to individual client needs - should be vetted against applicable legal and business requirements before application to a specific client

Source: Expert interviews, press search, client surveys

Increase hygiene protocols for shipping/receiving areas

Clean & disinfect

Office | Field

Description of potential intervention

Limit access of commercial drivers' to shipping area and separate them from staff

Increase hygiene protocols for shipping/receiving areas (e.g., sanitize all incoming packages)

Enforce masks, gloves, and other **PPE** when dealing with external packages

Where this has been done

Factories in China

Advanced electronics manufacturer in the US

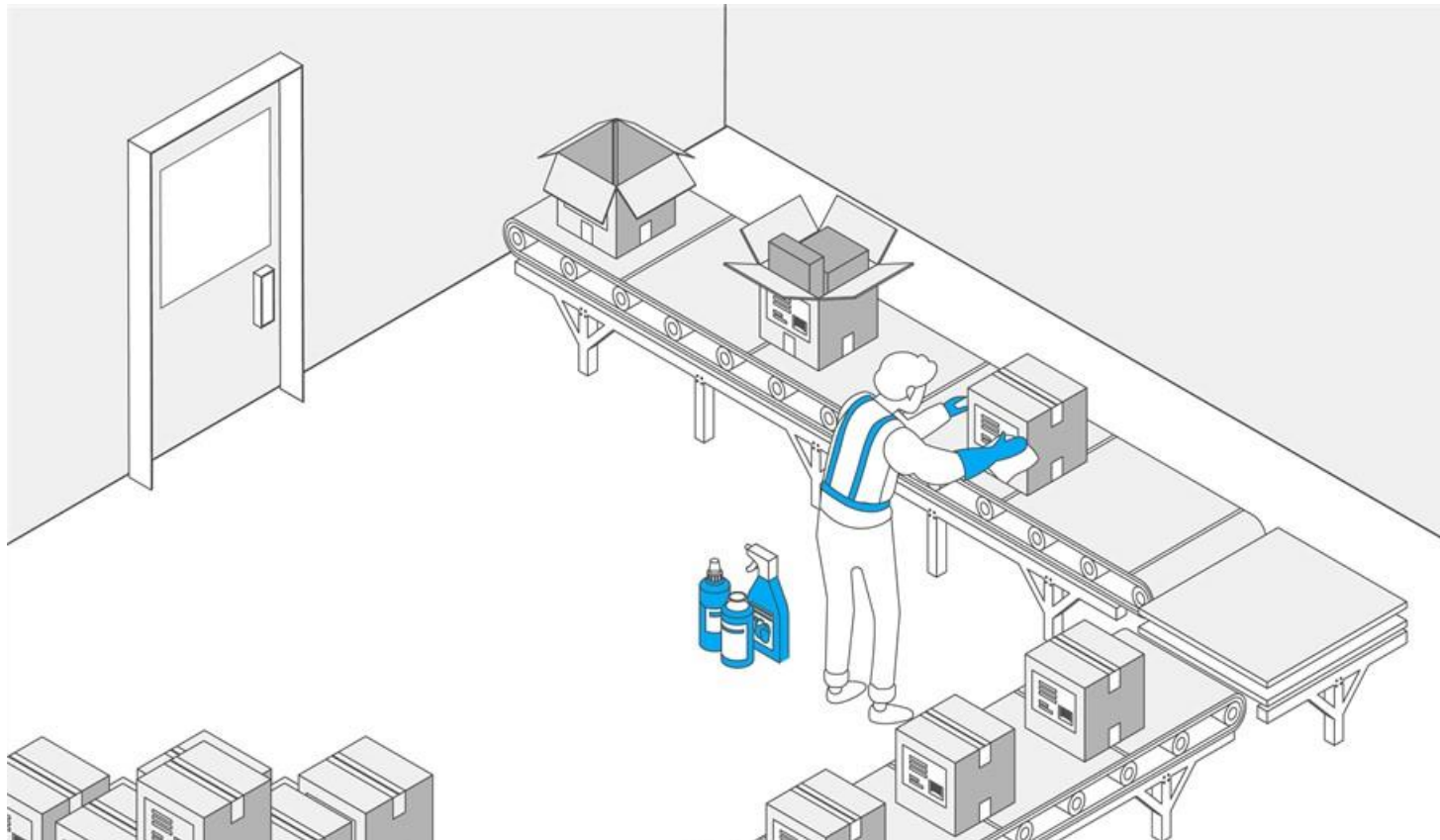

Restrict commercial access and disinfect external packages in shipping room

Does not reflect McKinsey guidance customized to individual client needs - should be vetted against applicable legal and business requirements before application to a specific client

Source: Expert interviews, press search, client surveys

Support employee safety practices in dormitories and accommodations as applicable

Separate in space & time

Office | Field

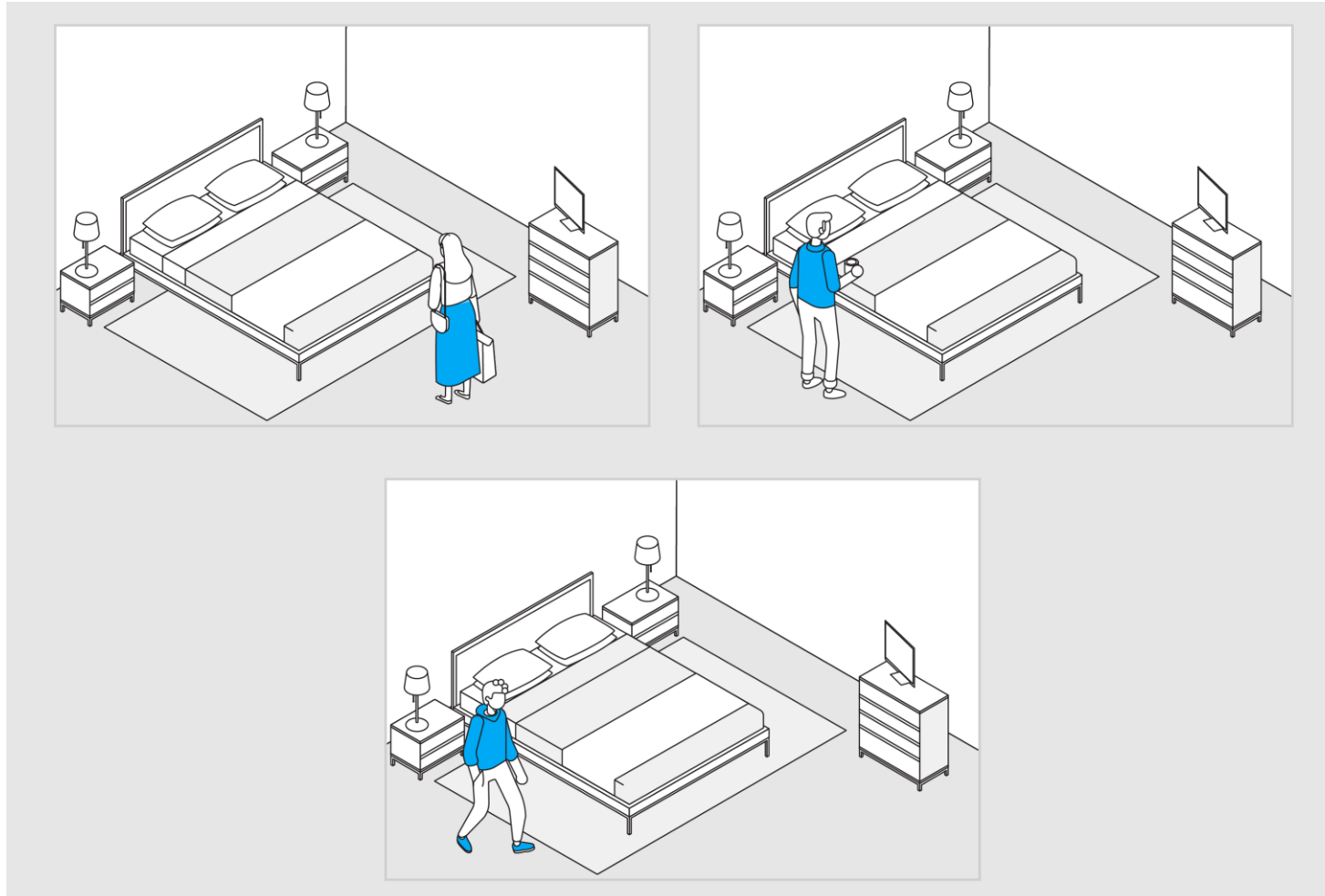

Description of potential intervention

Provide dormitories on work campus to reduce risk of employees contracting disease elsewhere or spreading to their families

Institute policy for all employees who leave campus to sleep must **re-do quarantine** when they return

Redesigned dormitories and common areas to enable distancing

Disallow employees to share corporate apartments and **provide isolated accommodations** instead

Where this has been done

Large electronics manufacturer in China

Automotive manufacturer in China

Does not reflect McKinsey guidance customized to individual client needs - should be vetted against applicable legal and business requirements before application to a specific client

Source: Expert interviews, press search, client surveys

Establish team or communication chain to collect questions and concerns from community



Collect suggestions/concerns from employees and prominently display FAQ

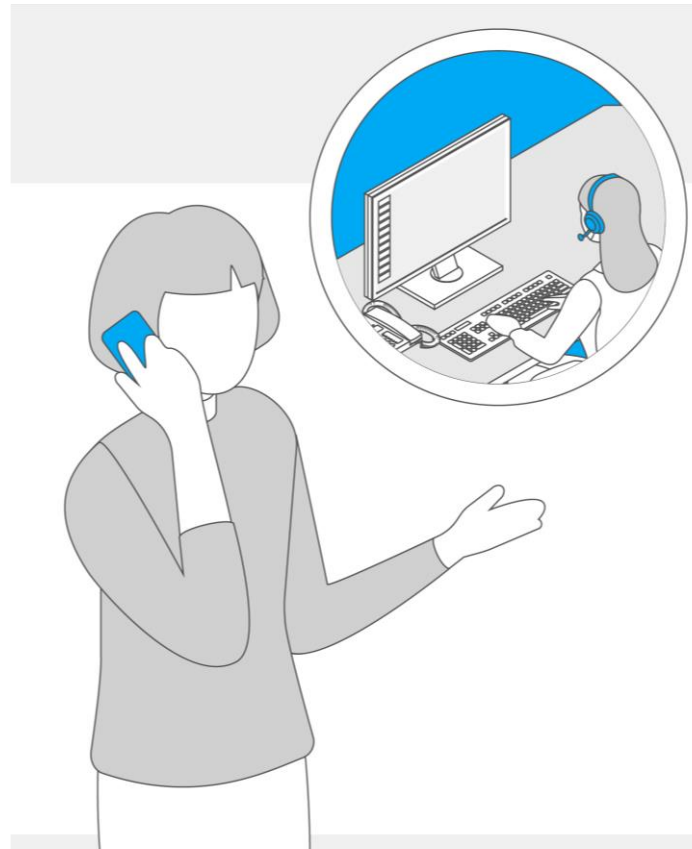

Setup a hotline for employees to report hygiene violations/concerns

Does not reflect McKinsey guidance customized to individual client needs - should be vetted against applicable legal and business requirements before application to a specific client

Source: Expert interviews, press search, client surveys

Drive safe behavior norms

Office | Field

Description of potential intervention

Collect feedback (queries and concerns) from frontline team members:

- Have supervisors collect queries and concerns from frontline team members every morning
- Setup a hotline to include suggestions/areas of improvement

Publish an updated Q&A list (as frequently as possible):

- Display on monitors / posters around the factory daily
- Upload to a corporate website

Where this has been done

Automotive manufacturer in China

McKinsey
& Company

Appendix

CONFIDENTIAL AND PROPRIETARY

Any use of this material without specific permission of McKinsey & Company
is strictly prohibited

Range of respirator and mask options provide different levels of performance

Generalization; selection should be made based on hazard assessment

NIOSH regulated

Observed incremental use in industry for COVID-19 protection

Critical supply		Reduces wearer's exposure to airborne particles	Protects others from wearer's respiratory emissions	Fluid resistant	Re-use	Relative unit cost	Comments
A	PAPR	<ul style="list-style-type: none"> Can filter >95% of particles >0.3 microns Good face seal 	Yes	Yes	Durable product	Highest	Provide high level protection with better comfort for high temperature jobs; more compatible with facial hair
	Full facepiece		Yes	Yes	Durable product	Higher	Better performance than disposable respirators for sweaty or dusty jobs
	Half facepiece		Yes	Yes	Durable product	Middle	Better performance than disposable respirators for sweaty or dusty jobs
	Surgical N95 respirator		Yes	Yes	Unknown	Lower	Generally used for health care providers
B	N95 respirator		Yes	No	Multi-use if cleaning is allowed	Lower	Generally used for health care providers and other high risk activities
C	Surgical mask	<ul style="list-style-type: none"> Some filtering performance Loose face seal 	Yes	Yes	Single use / replace daily in offices	Lower	Generally used for medium risk activities While a loose face seal blocks fewer particles it improves breathability
D	Non-spec products (commercial and homemade)	<ul style="list-style-type: none"> Varies 	Yes	Varies	Varies	Lower to middle	Wide range of alternatives with varied levels of performance and cost; typically for personal use

A: Durable respirators may provide greater protection and worker comfort relative to N95 respirators¹

Key metrics	Tight-fitting		Loose-fitting
	Half facepiece	Full facepiece	PAPR ²
Respiratory protection-APF ³	50	1000	25 ⁴
Min airflow rate	115 liters per min	115 liters per min	170 liters per min

OSHA recommends considering half facepiece, full facepiece, or powered air purifying (with HEPA filter) respirators as PPE options that provide greater protection and improved worker comfort relative to the N95 respirator¹

COVID-19 applicability

1. <https://www.osha.gov/Publications/OSHA3990.pdf> | 2. Powered Air-Purifying Respirator | 3. Assigned protection factor, a term used by OSHA to determine how well a respirator/filter combination will protect an individual from external contaminants; an APF of 25 means that no more than one-twenty fifth of the contaminants to which the worker is exposed will leak into the inside of the mask, <https://affygiility.com/potent-compound-corner/2017/10/19/the-proper-use-of-assigned-protection-factors-and-maximum-use-concentrations.html> | 4. APF of 25 without additional testing | 5. <https://www.ncbi.nlm.nih.gov/books/NBK294223> | 6. <https://www.osha.gov/laws-regs/regulations/standardnumber/1910/1910.134AppB2>, <https://www.cdc.gov/niosh/nppt/cleaning.html>

Tight-fitting facepieces and PAPRs may be more comfortable than disposable respirators for longer duration use, or if the user sweats heavily during work

Use of tight-fitting PAPRs requires fit testing; use of loose-fitting PAPRs does not require fit testing⁵

PAPRs protect the user by filtering out contaminants in the air and use a battery-operated blower to provide the user with clean air; this has a secondary effect of cooling the user, which is helpful in higher temperature operations, such as welding

Durable respirators may provide better fit than N95 respirators for users with facial hair

NIOSH and OSHA recommend routinely cleaning and disinfecting durable respirators⁶

A. Distinction between respirators and masks



Tight-fitting face seal³



Fluid resistant



Protects others from the wearer's respiratory emissions



CDC guidance for respirators:

- Non-surgical N95 respirators provide sufficient protection for health care providers against COVID-19 in most settings¹
- HCPs who are working in a sterile field or who may be exposed to high velocity splashes, sprays, or splatters of blood or body fluids should wear surgical respirators¹

OSHA guidance on lower risk tasks (i.e., low to medium):

- The PPE ensemble could include a face mask (e.g., surgical mask)²
- In rare situations would a respirator be required²

1. https://www.cdc.gov/niosh/npptl/topics/respirators/disp_part/default.html
 2. <https://www.osha.gov/Publications/OSHA3990.pdf>
 3. <https://www.cdc.gov/niosh/npptl/pdfs/UnderstandingDifference3-508.pdf>

B: Product breakdown for N95 respirators

Not exhaustive

Product breakdown for N95 Respirators

Spun-bond meltblown spunbond is 3-layer fabric that can be made inline or on separate extruders





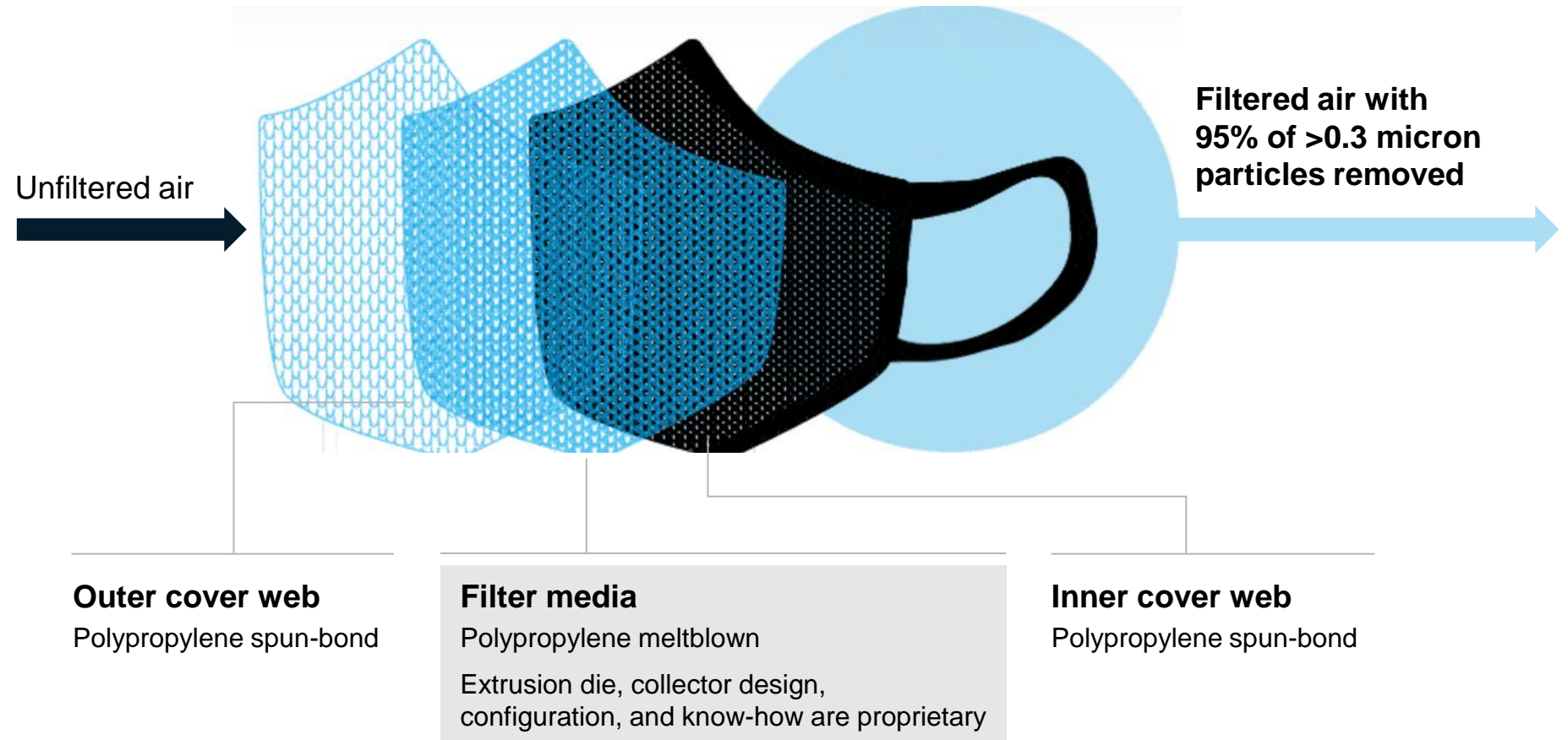



All the raw fabric materials **except the filter media** should be relatively straightforward to replicate across non-woven synthetic fabric mills

Filter media is significantly capacity constrained



1. CDC regulation 42 CFR 84.180, <https://www.cdc.gov/PPEInfo/Standards/Info/42CFR84180>

B: Supply of N95 respirators is limited, constrained by the specialized SMS fabric and thermoform process

Process step	Capacity	Output	Comments
 Refinery	 No constraint	 High grade polypropylene	Example refineries capable of high grade PP: Exxon, Chevron, Sinopec
 SMS (spunbond-meltblown-spunbond) mill	 Extreme constraint	 SMS roll stock (N95 quality)	Example mills (at capacity): SWM, 3M, Kimberly Clark, Transweb, Mytrex, Lydall, PFNonwovens, N95 capable equipment: Reifenhauser Reicofil (3.5mo lead time), Oerlikon
 Respirator thermoform converter	 Moderate constraint	 Finished N95 respirator	Example converters: Sunwell, 3M, Honeywell, Xinglong,

Process flow

Description of other options

- N95-equivalent or near-equivalent respirators from other countries
- Surgical masks

Reduction in demand, such as re-use

B: In crisis scenarios, CDC guidance indicates approved respirators under standards similar to NIOSH can be used

Country	Performance Standard	Acceptable Product Classification	Standards / Guidance Documents
Australia	AS/NZS 1716:2012	P3, P2	AS/NZS 1715:2009
Brazil	ABNT/NBR 13698:2011	PFF3, PFF2	Fundacentro CDU 614.894
China	GB 2626-2006	KN100, KP100, KN95, KP95	GB/T 18664-2002
Europe	EN 149-2001	FFP3, FFP2	EN 529:2005
Japan	JMHLW-2000	DS/DL3, DS/DL2	JIS T8150:2006
Korea	KMOEL-2017-64	Special, 1st	KOSHA GUIDE H-82-2015
Mexico	NOM-116-2009	N100, P100, R100, N99, P99, R99, P95, R95	NOM-116
US	NIOSH 42 CFR 84	N100, P100, R100, N99, P99, R99, P95, R95	OSHA 29CFR1910.134

C: Although not as effective as N95 respirators, surgical masks block out some aerosol particles

Fit test results are dependent on the structure of the user's face

Example fit test results

Particles 0.01-1 microns blocked, Percent

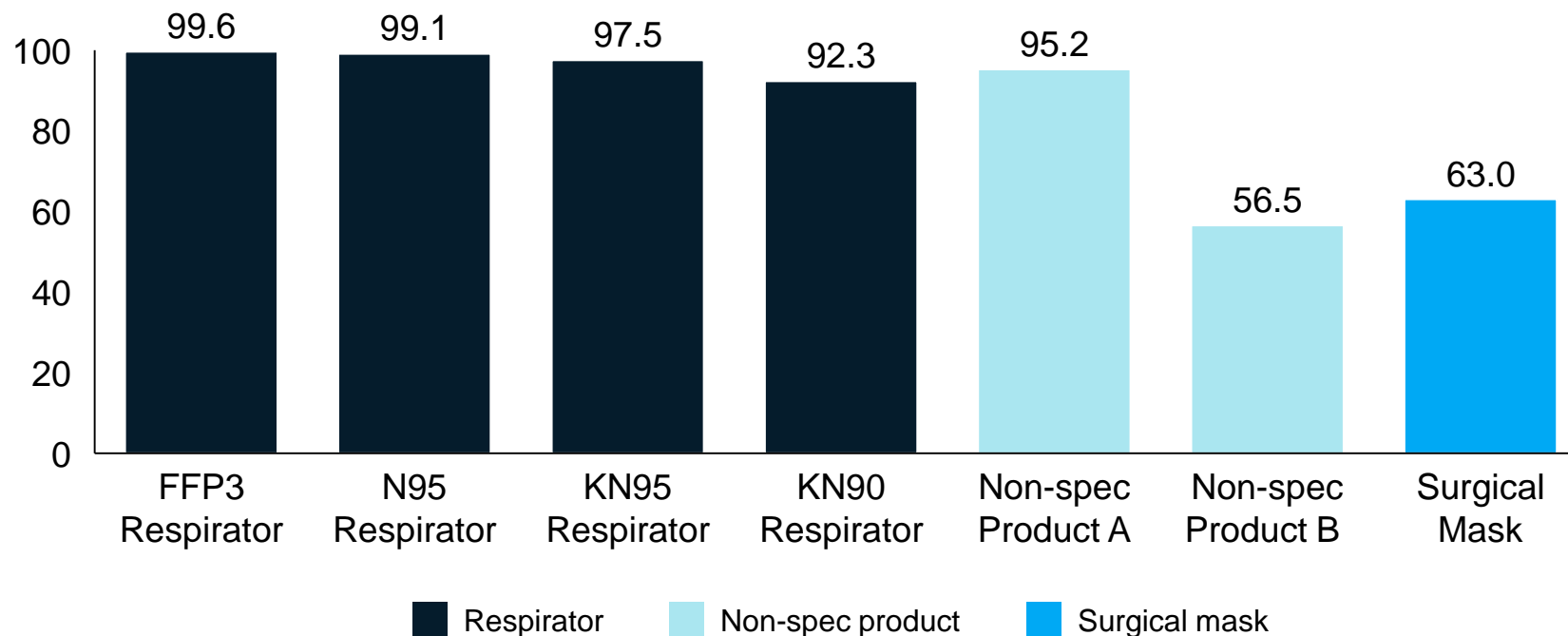

There are studies that successfully demonstrate a certain degree of efficacy of surgical masks despite the facial seal factors

Note: Specifications for respirators and masks often show filter efficiency, which is the inverse of the particle penetration of the material; a quantitative fit test (i.e., total leakage test), measures the ratio of particles inside the mask, compared to the particles outside the mask for a given user¹

1. <http://www.myhealthbeijing.com/children/my-personal-fit-testing-heres-the-best-pollution-mask-for-me/> | <https://multimedia.3m.com/mws/media/957730O/respirators-and-surgical-masks-contrast-technical-bulletin.pdf>

C: Surgical masks are designed with rapid mass manufacturing in mind

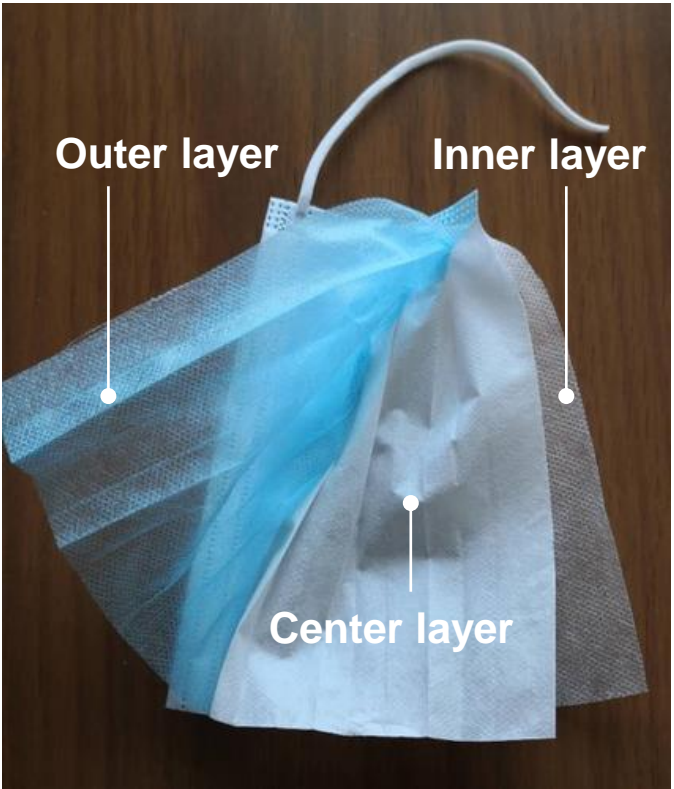

5 components of surgical masks

3 protective layers

1. **Inner layer**
 Material: Spunbonded non-woven fabric (Same material as the outside of disposable ice bag)
 Function: Enhance wearer's comfort.
2. **Center layer**
 Material: Polypropylene SMS non-woven fabric
 Function: Filter particles and bacteria according to the ASTM standards
3. **Outer layer**
 Material: Spunbonded non-woven fabric
 Function: Less soft than the inner layer, holds the desired color and is coated for fluid resistance

2 structural components

4. **Metal nose band**
5. **Elastic ear loops**

One customized machine cuts and bonds the 3 layers in 1 process

Material feed	3 fabrics are fed into the machine from rollers
Layering	Fabrics are laid in the desired accordion structure
Edge bonding	Edges of the mask are bonded using ultrasonic bonding machines or adhesives (ultrasonic provides stronger and more hygienic seal)
Die cut	The masks are stamped in the desired shape
+	
Component bonding	Metal nose bands and elastic ear loops are placed and ultrasonic bonded

D: CDC guidance for cloth face coverings

Cloth face coverings should

- Fit snugly but comfortably against the side of the face
- Be secured with ties or ear loops
- Include multiple layers of fabric
- Allow for breathing without restriction
- Be able to be laundered and machine dried without damage or change to shape

CDC recommends

- Wearing cloth face coverings in public settings where other social distancing measures are difficult to maintain (e.g., grocery stores and pharmacies), especially in areas of significant community-based transmission.
- CDC also advises the use of simple cloth face coverings to slow the spread of the virus and help people who may have the virus and do not know it from transmitting it to others. Cloth face coverings fashioned from household items or made at home from common materials at low cost can be used as an additional, voluntary public health measure.
- Cleaning the cloth face covering in a washing machine
- Taking care when removing the covering to not touch eyes, nose, or mouth, and wash hands immediately after removing

The cloth face coverings recommended are not surgical masks or N-95 respirators. Those are critical supplies that must continue to be reserved for healthcare workers and other medical first responders, as recommended by current CDC guidance.

Instructions provided for 3 types

1 Sewn cloth face covering

Materials

- Two 10"x6" rectangles of cotton fabric
- Two 6" pieces of elastic (or rubber bands, string, cloth strips, or hair ties)
- Needle and thread (or bobby pin)
- Scissors
- Sewing machine

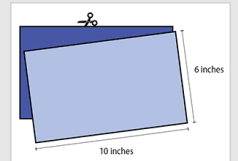

Steps

- Cut out two 10-by-6-inch rectangles of cotton fabric
- Run a 6-inch length of 1/8-inch wide elastic through the wider hem on each side of the mask
- Fold over the long sides 1/4 inch and hem. Then fold the double layer of fabric over 1/2 inch along the short sides and stitch down.
- Gently pull on the elastic so that the knots are tucked inside the hem. Gather the sides of the mask on the elastic and adjust so the mask fits your face. Then securely stitch the elastic in place to keep it from slipping

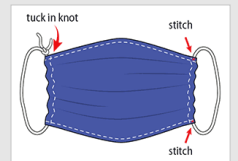
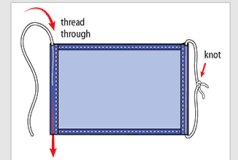

2 Quick cut T-shirt covering (new sew method)

Materials





- T-shirt
- Scissors

3 Bandana Face Covering (no sew method)

Materials

- Bandana (or square cotton cloth approximately 20"x20")
- Rubber bands (or hair ties)
- Scissors

Some non-medical applications for goggles were observed in cases but none for face-shields

Critical supply	Materials	COVID-19 applicability	Re-use	Observed in “return to work” case studies ²
Goggles (not safety glasses) 	Hard plastic (PVC, polycarbonate) Typically covers sides and above eyes Goggles should be appropriately fitted, indirectly-vented, with a manufacturer’s anti-fog coating	Provides the most reliable practical eye protection from splashes, sprays, and respiratory droplets Must be snugly fit across the brow to provide best protection	Reusable for long periods of time if properly sanitized (several weeks) Manufacturers can apply anti scratch coatings or use thicker gauge plastic in order to extend life ¹	 Select applications observed
Face-shield 	Soft plastic (PVC, polycarbonate, polyethylene)	Used in higher risk COVID-19 environments that will expose wearer to fluid splashes (e.g., intubations, vomiting patient, etc.) Provides additional protection to other facial areas and neck	Typically reusable for short periods of time if properly sanitized (2-3 days) Face shield usability is determined by wearer (i.e., view is clear of obstruction, no limiting scratches or damage)	 No applications observed

ANSI Z87.1 D3 defines design requirements for eye protection that protects against splash, droplets, and sprays

1. Derived from health care expert interview
 2. Industry and PPE expert interviews

Different protective equipment used across industries

Note:
ANSI/AAMI PB70 is a standard that evaluates the barrier effectiveness of surgical gowns and isolation gowns





	Medical		Chemical/Industrial				Industrial		
	Isolation gown (SMS)	Surgical gown (AAMI Class 2-4)	Cleanroom Frock (SMS/Polyester)	Chemical resistant coverall (HDPE/Tyvek)	Chemical resistant apron	Disposable Apron (nylon/PVC)	Coveralls (polyester/cotton)	Cleanroom ESD Smock (SMS/Polyester)	Lab Coat (polyester)
Ability to meet AAMI Level 1 Protection ¹	●	●	◐	●	◐	◐	◐	◐	◐
Reuse or cleaning potential ²	◐	◐	◐	◐	●	◐	●	●	●
Long-term comfort, breathability	●	●	◐	◐	◐	◐	◐	●	●
Ease of manufacture	●	◐	◐	◐	◐	●	◐	◐	◐

Limited non-medical applications of gowns / body protection observed in cases

1. Unless otherwise certified, these may meet at least AAMI Class I. However, this needs to be validated; AAMI Level 1 is a measure of liquid barrier performance and expected barrier effectiveness is "Minimal water resistance (some resistance to water spray)"
2. Includes multiple uses and/or cleanability
3. Qualitative assessment from one concept review based on material technical data sheets –criteria and assessment needs to be validated by any potential user



CDC recommends nitrile and latex gloves for OSHA-equivalent high-risk activities

Disposable glove material	Characteristics ¹	Applications	Relative unit cost	Scarcity ²
Nitrile 	Stronger than latex or vinyl, with fit, feel, and comfort rivaling that of latex. 3x puncture resistance and higher abrasion and chemical resistance than latex.	<ul style="list-style-type: none"> • Medical • Customer services (e.g., security, tattoo artists, salon) • Industrial (e.g., automotive, manufacturing, janitorial, plumbing, paint shop, chemical, food processing) 	Higher	Moderate
Latex 	Most elastic, resilient, and consistent-fitting glove material; more flexible and offers greater tactile sensitivity than nitrile Latex allergies in <1% of US population	<ul style="list-style-type: none"> • Medical (e.g., examination, laboratory) • Industrial (e.g., automotive, janitorial, paint shops, printing) 	Middle	Moderate
Vinyl 	Comfortable fit that is looser than latex or nitrile; economical option where frequent glove changes are required	<ul style="list-style-type: none"> • Medical • Industrial (e.g., food service) 	Lower	Moderate
Polyethylene 	Most affordable glove material, good for short duration tasks and frequent glove changes	<ul style="list-style-type: none"> • Customer service (e.g., salon, cosmetics) • Industrial (e.g., food service) • Arts and crafts 	Lowest	Low





1.AMMEX glove guide – April 2019

2.High scarcity = low availability

3.<https://www.cdc.gov/coronavirus/2019-ncov/hcp/respirator-use-faq.html>

CDC recommends for high-risk medical applications, (i.e., caring for suspected or confirmed COVID-19 patients)³

Wide-range of sanitizers and disinfectants used for COVID-19

Critical supply		CDC recommended	Additional comments from CDC
Soap and water	Any soap, applied for 20 seconds ¹		Wash your hands often with soap and water for at least 20 seconds especially after you have been in a public place, or after blowing your nose, coughing, or sneezing ¹
Hand sanitizers	Alcohol ² Ethanol (>60% concentration) Isopropanol (>70%)		Alcohol based hand rubs are recommended over hand washing in most cases because they are less damaging to skin and achieve greater compliance ²
	Non-alcohol Benzalkonium chloride Benzethonium chloride Chloroxylenol Povidone-iodine Others		Available evidence indicates benzalkonium chloride has less reliable activity against coronavirus than either of the alcohols ²
Equipment / surface disinfectants ³	Chlorine bleach Alcohol Hydrogen peroxide Ammonia Others		Practice routine cleaning of frequently touched surfaces (e.g., tables, doorknobs, light switches, handles, desks, toilets, faucets, sinks, and electronics) with household cleaners and EPA-registered disinfectants that are appropriate for the surface, following label instructions

Alcohol is an effective antiviral because it denatures the structure of proteins, including the envelope of viruses⁴

While there may be sourcing challenges for ABHRs are a relatively simple formulation of commodity chemicals (see next page)

1. <https://www.cdc.gov/coronavirus/2019-ncov/prevent-getting-sick/prevention.html>
 2. <https://www.cdc.gov/coronavirus/2019-ncov/infection-control/hcp-hand-hygiene-faq.html>
 3. <https://www.epa.gov/pesticide-registration/list-n-disinfectants-use-against-sars-cov-2>
 4. <https://www.cdc.gov/infectioncontrol/guidelines/disinfection/disinfection-methods/chemical.html>

Product breakdown: alcohol-based hand rub (ABHR) raw material inputs

	Ethyl alcohol	OR	Isopropyl alcohol	+	Glycerol (glycerin)	+	Hydrogen peroxide
Purpose	Antiseptic		Antiseptic		Humectant (skin care)		Antibacterial for solution
FDA guidance¹	Denatured, at least 94.9% ethanol by vol		No specifications		Food grade ³		Concentrate USP or Topical Solution USP
WHO guidance²	Ethanol 96%		Isopropyl alcohol 99.8%		Glycerol 98%		Hydrogen peroxide 3-6%

1. <https://www.fda.gov/media/136289/download>

2. https://www.who.int/gpsc/5may/Guide_to_Local_Production.pdf

3. Meets United States Pharmacopoeia (USP) or Food Chemical Codex (FCC) grade requirements

4. FDA guidelines have been endorsed by the WHO and CDC

Source: FDA Policy for Temporary Compounding of Certain Alcohol-Based Hand Sanitizer Products During the Public Health Emergency Immediately Effect Guidance for Industry (as of March 27 2020), WHO-recommended Handrub Formulations; CDC

ABHR is made up of commodity chemicals that meet United States Pharmacopoeia (USP) or Food Chemical Codex (FCC) standards

As an alternative to traditional sourcing, the FDA has provided guidelines for new producers to make alcohol-based hand rub⁴